

ifm electronic



Operating instructions
Pressure sensor

efector500[®]

PN70xx

UK

706136 / 00 01 / 2012

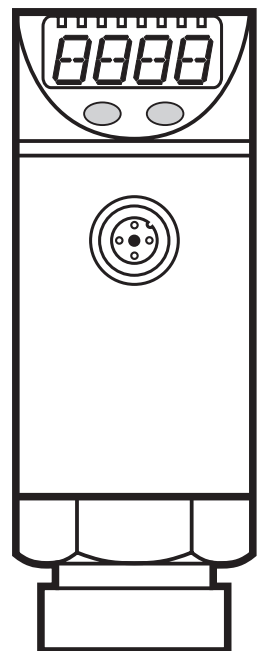

Contents

1	Preliminary note.....	3
1.1	Symbols used	3
2	Safety instructions	3
3	Functions and features	4
4	Function.....	5
4.1	Communication, parameter setting, evaluation	5
4.2	Switching function.....	5
4.3	Diagnostic function	6
5	Installation.....	6
6	Electrical connection.....	7
7	Operating and display elements	8
8	Menu.....	9
8.1	Menu structure.....	9
8.2	Explanation of the menu.....	10
9	Parameter setting	11
9.1	General parameter setting.....	11
9.2	Configuring the display (optional).....	13
9.3	Setting the output signals	13
9.3.1	Setting of the output function.....	13
9.3.2	Setting of the switching limits	13
9.4	User settings (optional)	14
9.4.1	Setting of a time delay for the switching signals.....	14
9.4.2	Setting of the output logic for the switching outputs	14
9.4.3	Setting of the damping for the switching outputs.....	14
9.5	Service functions	14
9.5.1	Reading the min./max. values for the system pressure.....	14
9.5.2	Reset all parameters to factory setting.....	14
10	Operation.....	15
10.1	Reading of the set parameters	15
10.2	Fault indication	15
11	Scale drawing	16
12	Technical data.....	16
12.1	Setting ranges	18

1 Preliminary note

1.1 Symbols used

- ▶ Instruction
- > Reaction, result
- [...] Designation of pushbuttons, buttons or indications
- Cross-reference



Important note:

Non-compliance can result in malfunctions or interference.

UK

2 Safety instructions

- Please read this document prior to set-up of the unit. Ensure that the product is suitable for your application without any restrictions.
- If the operating instructions or the technical data are not adhered to, personal injury and/or damage to property can occur.
- Check the compatibility of the product materials (→ chapter 12 Technical data) with the media to be measured in all applications.
- Use in gases at pressures > 25 bar only after contacting the manufacturer ifm.

3 Functions and features

The unit monitors the system pressure of machines and plants.

Applications

Type of pressure: relative pressure

Order no.	Measuring range		Permissible overpressure		Bursting pressure	
	bar	PSI	bar	PSI	bar	PSI
PN7000	0...400	0...5 800	600	8 700	1 000	14 500
PN7001	0...250	0...3 625	400	5 800	850	12 300
PN7002	0...100	0...1 450	300	4 350	650	9 400
PN7003	0...25	0...363	150	2 175	350	5 075
PN7004	-1...10	-14.5...145	75	1 087	150	2 175
PN7006	0...2.5	0...36.3	20	290	50	725
PN7007	0...1	0...14.5	10	145	30	450
PN7009	-1...1	-14.5...14.5	20	290	50	725
PN7060	0...600	0...8 700	800	11 600	1 200	17 400

MPa = bar ÷ 10 / kPa = bar × 100



Avoid static and dynamic overpressure exceeding the given overload pressure by taking appropriate measures.

The indicated bursting pressure must not be exceeded.

Even if the bursting pressure is exceeded only for a short time, the unit may be destroyed. NOTE: Risk of injury!

Use in gases at pressures > 25 bar only after contacting the manufacturer ifm.

High-pressure units (400 bar, 600 bar) are supplied with an integrated damping device to comply with the regulations for UL approval and to avoid any risk of injury in case of bursting when bursting pressure is exceeded.

- When the damping device is removed the damping device can become unusable.
- When the damping device is removed the unit can no longer be used under UL conditions.

If you have any questions, please contact ifm electronic's sales specialists.

4 Function

4.1 Communication, parameter setting, evaluation

- The unit displays the current process value.
- It generates 2 output signals according to the parameter setting.

OUT1	• Switching signal for process value; IO-Link.
OUT2	2 options • Switching signal for process value. • Diagnostic signal (output 2 is inactive in case of a fault).

- The following function is available via IO-Link (OUT1):
Reading the current process value, changing the parameters and transferring them to other units of the same type using the FDT service program ifm Container or other parameter setting tools with IO-Link capability.
The program library of the available DTM objects and the IO Device Description (IODD) are available at www.ifm.com → Service → Download.

4.2 Switching function

OUT_x changes its switching state if it is above or below the set switching limits (SP_x, rP_x). The following switching functions can be selected:

- Hysteresis function / normally open: [OU_x] = [Hno] (→ fig. 1).
- Hysteresis function / normally closed: [OU_x] = [Hnc] (→ fig. 1).

First the set point (SP_x) is set, then the reset point (rP_x) with the requested difference.

- Window function / normally open: [OU_x] = [Fno] (→ fig. 2).
- Window function / normally closed: [OU_x] = [Fnc] (→ fig. 2).

The width of the window can be set by means of the difference between SP_x and rP_x. SP_x = upper value, rP_x = lower value.

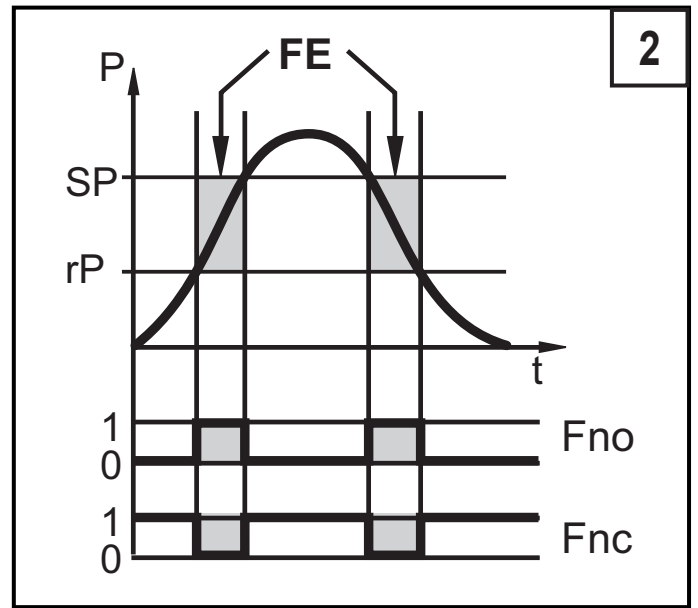
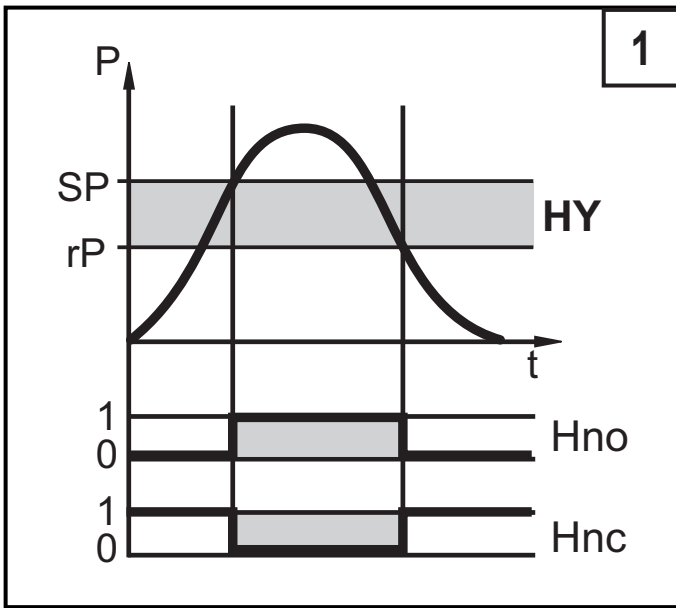

P = system pressure; HY = hysteresis; FE = window

4.3 Diagnostic function

Output 2 is used as diagnostic output based on the DESINA specification if [OU2] = [dESI].

- If there is no fault, the output is switched and carries UB+ (if P-n = PnP) or UB- (if P-n = nPn).
- In case of malfunctions in the following areas, the output is inactive:
 - Measuring cell defect,
 - short circuit in output 1

5 Installation



Before mounting and removing the sensor, make sure that no pressure is applied to the system.

- ▶ Insert the unit in a G $\frac{1}{4}$ process connection.
- ▶ Tighten firmly.

6 Electrical connection



The unit must be connected by a qualified electrician.

The national and international regulations for the installation of electrical equipment must be adhered to.

Voltage supply to EN50178, SELV, PELV.

- ▶ Disconnect power.
- ▶ Connect the unit as follows:

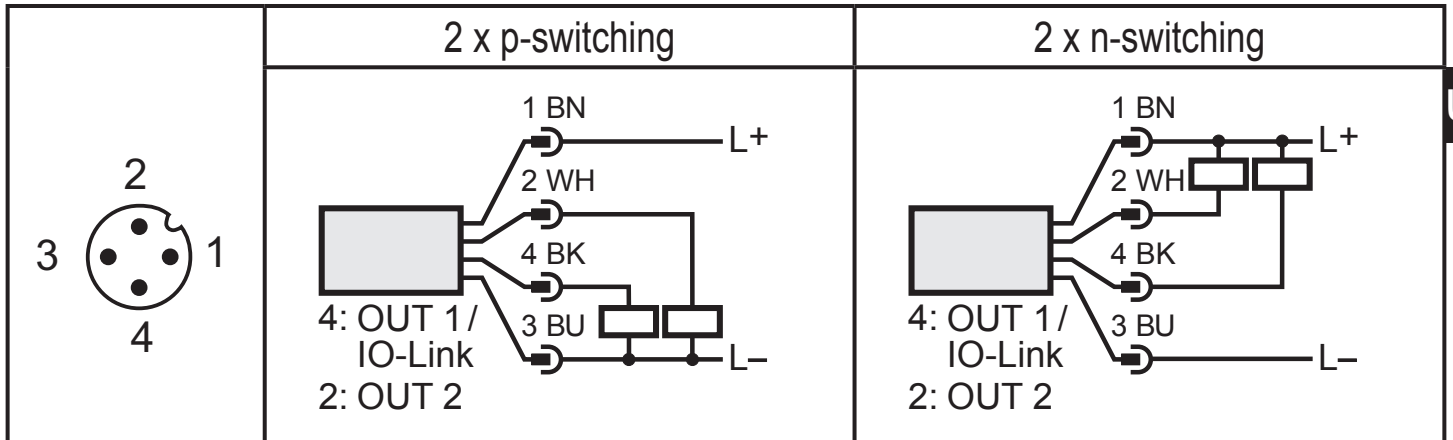

UK

Pin 1	Ub+
Pin 3	Ub-
Pin 4 (OUT1)	• binary switching output pressure monitoring; IO-Link
Pin 2 (OUT2)	• binary switching output if [OU2] = [Hno], [Hnc], [Fno] or [Fnc] • diagnostic output if [OU2] = [dESI]

Core colours of ifm sockets:

1 = BN (brown), 2 = WH (white), 3 = BU (blue), 4 = BK (black)

7 Operating and display elements

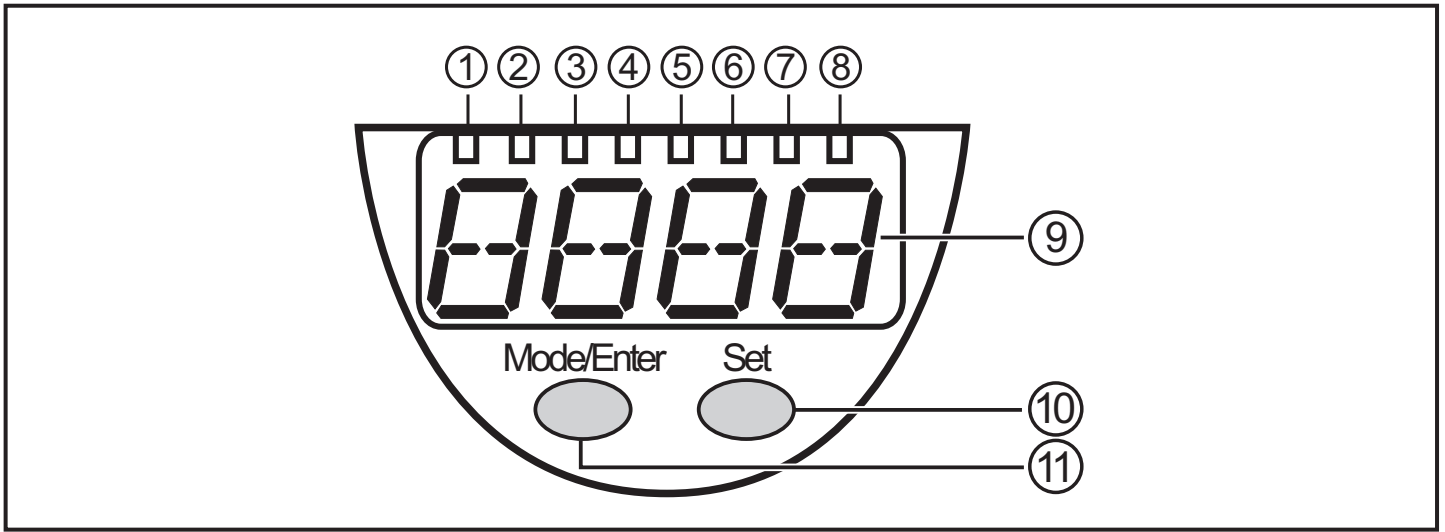

1 to 8: Indicator LEDs

- LED 1 to LED 4 = system pressure in unit of measurement as indicated on the label.
- LED 4 not used for units with 3 adjustable units of measurement.
- LEDs 5 and 6 not used.
- LED 7, LED 8 = switching state of the corresponding output.

9: Alphanumeric display, 4 digits

- Indication of the current system pressure.
- Indication of the parameters and parameter values.

10: Set pushbutton

- Setting of the parameter values (scrolling by holding pressed, incremental by pressing briefly).

11: Mode/Enter pushbutton

- Selection of the parameters and acknowledgement of the parameter values.

8 Menu

8.1 Menu structure

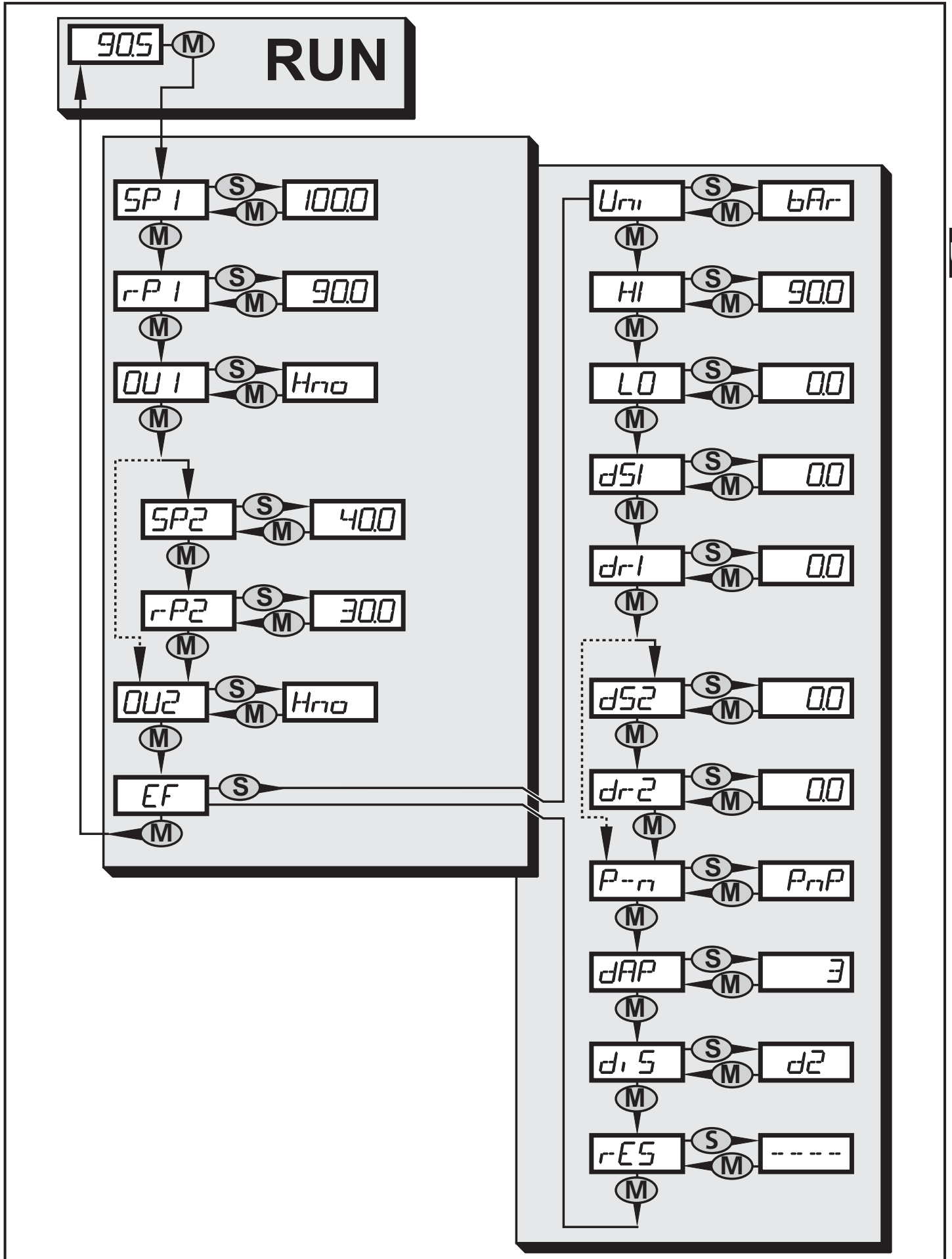

UK

8.2 Explanation of the menu

SP1/rP1	Upper / lower limit value for system pressure at which OUT1 switches.
SP2/rP2	Upper / lower limit value for system pressure at which OUT2 switches.
OU1	Output function for OUT1: <ul style="list-style-type: none"> Switching signal for the pressure limit values: hysteresis function [H ..] or window function [F ..], either normally open [. no] or normally closed [. nc].
OU2	Output function for OUT2: <ul style="list-style-type: none"> Switching signal for the pressure limit values: hysteresis function [H ..] or window function [F ..], either normally open [. no] or normally closed [. nc]. Diagnostic signal [OU2] = dESI.
EF	Extended functions / opening of menu level 2.
Uni	Standard unit of measurement for system pressure.
HI	Maximum value memory for system pressure.
LO	Minimum value memory for system pressure (only PN7004 and PN7009).
dS1/dS2	Switch-on delay for OUT1 / OUT2.
dr1/dr2	Switch-off delay for OUT1 / OUT2.
P-n	Output logic: pnp / npn.
dAP	Damping for the switching outputs.
diS	Update rate and orientation of the display.
rES	Restore factory settings.

9 Parameter setting

During parameter setting the unit remains in the operating mode. It continues its monitoring function with the existing parameters until the parameter setting has been completed.

9.1 General parameter setting

3 steps must be taken for each parameter setting:

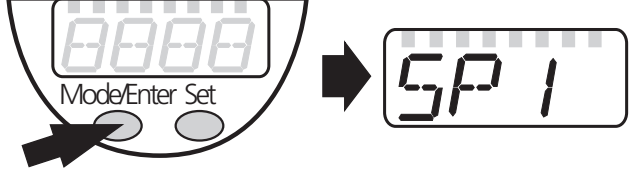
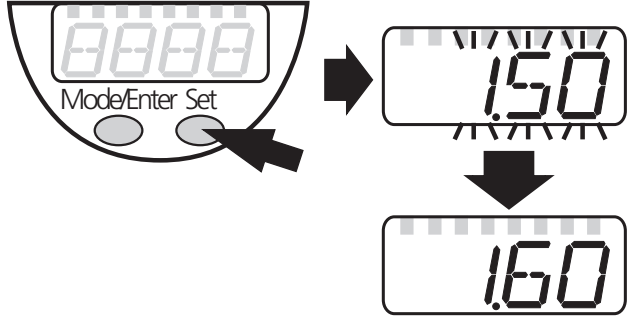
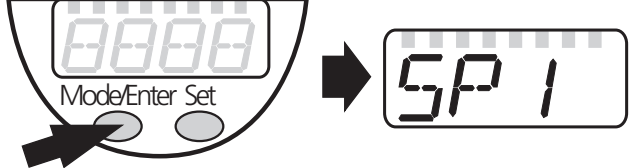
<p>1</p>	<p>Parameter selection</p> <ul style="list-style-type: none"> ▶ Press [Mode/Enter] until the requested parameter is displayed. 	
<p>2</p>	<p>Setting of the parameter value</p> <ul style="list-style-type: none"> ▶ Press [Set] and keep it pressed. > Current setting value of the parameter flashes for 5 s. > After 5 s: setting value is changed: incrementally by pressing the button once or continuously by keeping the button pressed. 	
<p>Numerical values are incremented continuously. To reduce the value: let the display move to the maximum setting value. Then the cycle starts again at the minimum setting value.</p>		
<p>3</p>	<p>Acknowledgement of the parameter value</p> <ul style="list-style-type: none"> ▶ Press [Mode/Enter] briefly. > The parameter is displayed again. The new setting value is stored. 	
<p>Setting of other parameters:</p> <ul style="list-style-type: none"> ▶ Start again with step 1. 		
<p>Finishing the parameter setting:</p> <ul style="list-style-type: none"> ▶ Press [Mode/Enter] several times until the current measured value is displayed or wait for 15 s. > The unit returns to the operating mode. 		

UK

- If [SLoc] is displayed when attempting a modification of a parameter value, the sensor is locked via software. This locking can only be removed via a parameter setting software.

- Change from menu level 1 to menu level 2:

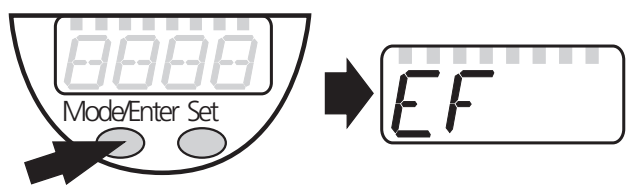
<ul style="list-style-type: none"> ▶ Press [Mode/Enter] until [EF] is displayed. <p>If the submenu is protected with an access code, "Cod1" flashes in the display.</p> <ul style="list-style-type: none"> ▶ Press [Set] and keep it pressed until the valid code no. is displayed. ▶ Press [Mode/Enter] briefly. <p>On delivery by ifm electronic: no access restriction.</p>	
---	--

<ul style="list-style-type: none"> ▶ Press [Set] briefly. > The first parameter of the sub-menu is displayed (here: [Uni]). 	
--	--

With the user interface of the ifm Container program:

- ▶ Activate the [EF] button.

If menu level 2 is protected by an access code, the input field for the code no. is activated.

- ▶ Enter valid code no.

- Locking / unlocking

The unit can be locked electronically to prevent unintentional settings.

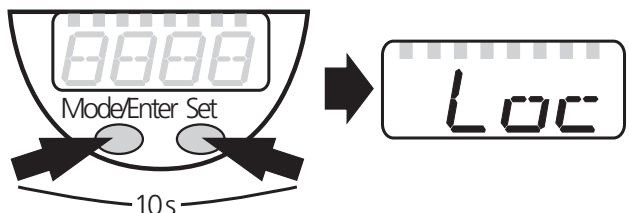
<ul style="list-style-type: none"> ▶ Make sure that the unit is in the normal operating mode. ▶ Press [Mode/Enter] + [Set] for 10 s. > [Loc] is displayed. 	
--	--

During operation: [Loc] is briefly displayed if you try to change parameter values.

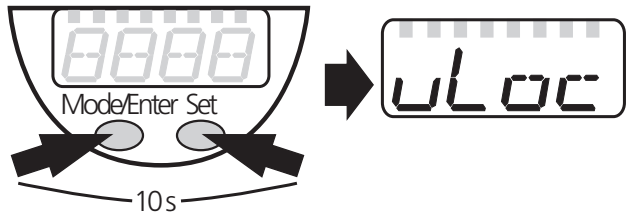

<p>For unlocking:</p> <ul style="list-style-type: none"> ▶ Press [Mode/Enter] + [Set] for 10 s. > [uLoc] is displayed. 	
---	--

On delivery: unlocked.

- Timeout:

If no button is pressed for 15 s during parameter setting, the unit returns to the operating mode with unchanged values.



9.2 Configuring the display (optional)

<ul style="list-style-type: none"> ▶ Select [Uni] and set the unit of of measurement: <ul style="list-style-type: none"> - [bar], [mbar], [MPa], [kPa], [PSI], for PN7007 and PN7009 in addition [inHg]. 	
<ul style="list-style-type: none"> ▶ Select [diS] and set update rate and orientation of the display: <ul style="list-style-type: none"> - [d1]: Update of the measured value every 50 ms. - [d2]: Update of the measured value every 200 ms. - [d3]: Update of the measured value every 600 ms. - [rd1], [rd2], [rd3]: Display like d1, d2, d3; rotated by 180°. - [OFF]: The display is deactivated in the operating mode. 	



UK

9.3 Setting the output signals

9.3.1 Setting of the output function

<ul style="list-style-type: none"> ▶ Select [OU1] and set the function: <ul style="list-style-type: none"> - [Hno] = hysteresis function / normally open - [Hnc] = hysteresis function / normally closed, - [Fno] = window function / normally open, - [Fnc] = window function / normally closed 	
<ul style="list-style-type: none"> ▶ Select [OU2] and set the function: <ul style="list-style-type: none"> - [Hno] = hysteresis function / normally open, - [Hnc] = hysteresis function / normally closed, - [Fno] = window function / normally open, - [Fnc] = window function / normally closed, - [dESI] = output 2 is used as a diagnostic output. 	

9.3.2 Setting of the switching limits

<ul style="list-style-type: none"> ▶ Select [SP1] / [SP2] and set the value at which the output switches. 	
<ul style="list-style-type: none"> ▶ Select [rP1] / [rP2] and set the value at which the output switches off. rPx is always smaller than SPx. The unit only accepts values which are lower than the value for SPx. 	

9.4 User settings (optional)

9.4.1 Setting of a time delay for the switching signals

<p>[dS1] / [dS2] = switch-on delay for OUT1 / OUT2. [dr1] / [dr2] = switch-off delay for OUT1 / OUT2.</p> <p>▶ Select [dS1], [dS2], [dr1] or [dr2] and set a value between 0.2 and 50 s (at 0.0 the delay time is not active).</p>	<p>dS1 dS2 dr1 dr2</p>
---	---

9.4.2 Setting of the output logic for the switching outputs

<p>▶ Select [P-n] and set [PnP] or [nPn].</p>	<p>P-n</p>
---	------------

9.4.3 Setting of the damping for the switching outputs

<p>▶ Select [dAP] and set a value. dAP value = response time between pressure change and change of the switching status in milliseconds. Damping has also an effect on the display and the IO-Link process value. The following fix values can be set; they define the switching frequency (f) of the output:</p> <table border="1" data-bbox="97 1111 1264 1245"> <tr> <td>dAP</td> <td>3</td> <td>6</td> <td>10</td> <td>17</td> <td>30</td> <td>60</td> <td>125</td> <td>250</td> <td>500</td> </tr> <tr> <td>f [Hz]</td> <td>170</td> <td>80</td> <td>50</td> <td>30</td> <td>16</td> <td>8</td> <td>4</td> <td>2</td> <td>1</td> </tr> </table>	dAP	3	6	10	17	30	60	125	250	500	f [Hz]	170	80	50	30	16	8	4	2	1	<p>dAP</p>
dAP	3	6	10	17	30	60	125	250	500												
f [Hz]	170	80	50	30	16	8	4	2	1												

9.5 Service functions

9.5.1 Reading the min./max. values for the system pressure

<p>▶ Select [HI] or [LO], press [Set] briefly. [HI] = maximum value, [LO] = minimum value.</p> <p>Delete memory:</p> <p>▶ Select [HI] or [LO].</p> <p>▶ Press [Set] until [----] is displayed.</p> <p>▶ Press [Mode/Enter] briefly.</p> <p>[LO] is available only for PN7004 and PN7009.</p>	<p>HI LO</p>
---	---------------------------

9.5.2 Reset all parameters to factory setting

<p>▶ Select [rES].</p> <p>▶ Press [Set] and keep it pressed until [----] is displayed.</p> <p>▶ Press [Mode/Enter] briefly.</p> <p>It is recommended to take down your own settings in the table before carrying out a reset (→13 Factory setting).</p>	<p>rES</p>
---	------------

10 Operation

After power on, the unit is in the Run mode (= normal operating mode). It carries out its measurement and evaluation functions and provides output signals according to the set parameters.

Operating indications → chapter 7 Operating and display elements.

10.1 Reading of the set parameters

- ▶ Press [Mode/Enter] until the requested parameter is displayed.
- ▶ Press [Set] briefly.
- > The unit displays the corresponding parameter value for about 15 s. After another 15 s the unit returns to the Run mode.

UK

10.2 Fault indication

[OL]	Overload pressure (measuring range exceeded)
[UL]	Underload pressure (below measuring range)
[SC1]	Short circuit in OUT1*
[SC2]	Short circuit in OUT2*
[SC]	Short circuit in both outputs*
[Err]	Flashing: internal fault

*The output concerned is switched off as long as the short circuit exists.

The messages SC1, SC2, SC, and Err are shown even if the display is switched off.

11 Scale drawing

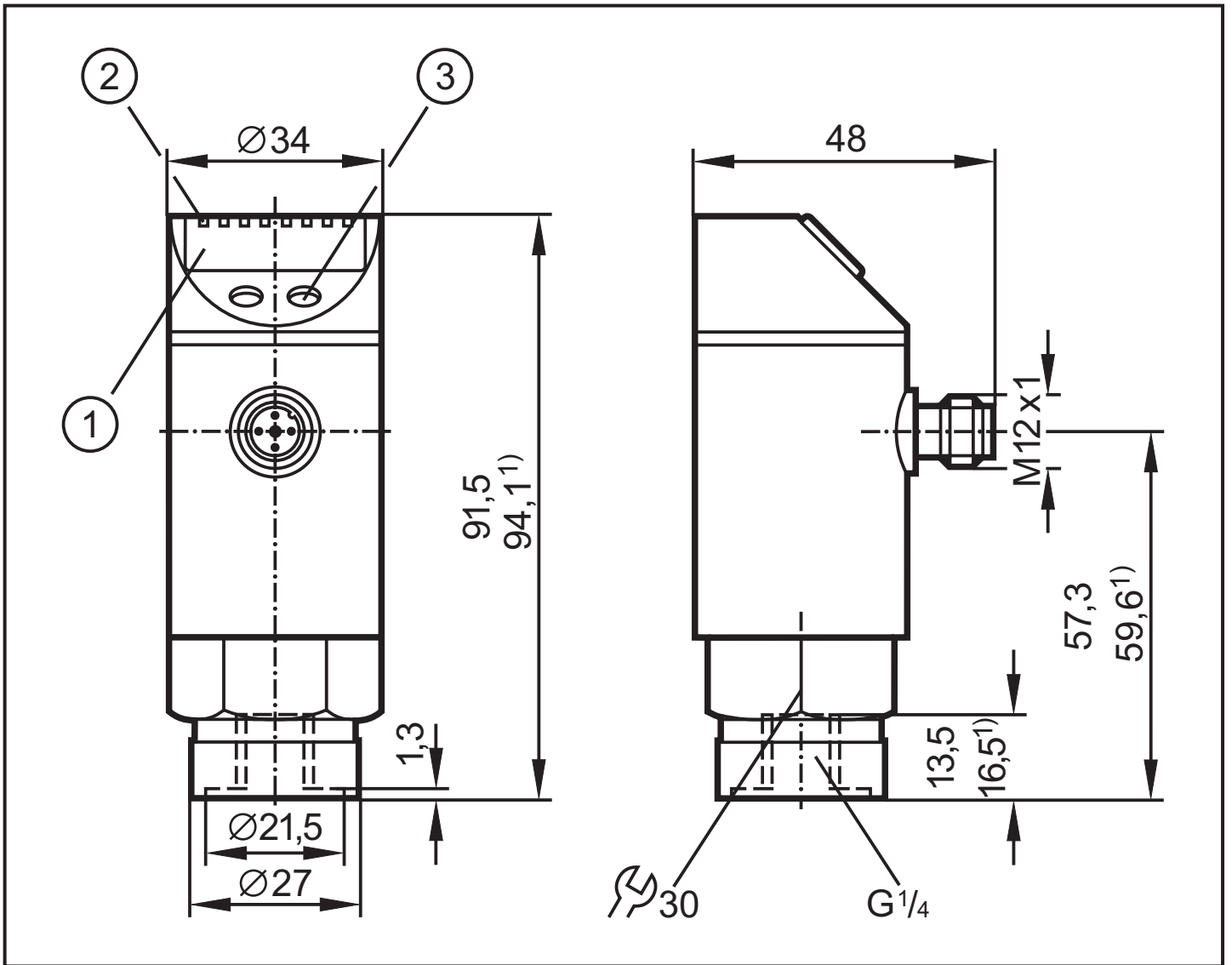

Dimensions are in millimeters

¹) = dimensions for PN7000 and PN7060

1: display

2: LED's

3: programming button

12 Technical data

Operating voltage [V].....	18...36 DC ¹⁾
Current consumption [mA].....	< 50
Current rating per switching output [mA]	250
Reverse polarity protection, overload protection	up to 40 V
Short-circuit protection; Integrated watchdog	
Voltage drop [V]	< 2
Power-on delay time [s]	0.3
Switching frequency [Hz]	max.170

Communication interface	IO-Link 1.1
Baud rate [kBAUD]	38.4
Accuracy / deviations (in % of the span)	
- Set point accuracy	< ± 0.5
- Deviation of the characteristics	< ± 0.25 (BFSL) / < ± 0.5 (LS)
- Hysteresis.....	< 0.25 (1.0 for PN7060)
- Repeatability (in case of temperature fluctuations < 10 K).....	< ± 0.1
- Long-term stability (in % of the span per 6 months)	< ± 0.05
- Temperature coefficients (TEMPCO) in the compensated temperature range 0 ... 80 °C (in % of the span per 10 K)	
- Greatest TEMPCO of the zero point / of the span	< ± 0.2 / < ± 0.2
Materials (wetted parts)	stainless steel (303S22); ceramics; FPM (Viton)
Housing material	stainless steel (304S15); stainless steel 316L / 1.4404; PBTP (Pocan); PEI; FPM (Viton) ²⁾
Protection	IP 67 III ³⁾
Protection	IP 65 III ⁴⁾
Insulation resistance [MΩ]	> 100 (500 V DC)
Shock resistance [g]	50 (DIN / IEC 68-2-27, 11ms)
Vibration resistance [g]	20 (DIN / IEC 68-2-6, 10 - 2000 Hz)
Switching cycles min.	100 million (50 million for PN7060)
Operating temperature [°C]	-20...80 (UB < 32 V) / -20...60 (UB > 32 V)
Medium temperature [°C]	-25 ... +80
Storage temperature[°C].....	-40 ... +100
EMC EN 61000-4-2 ESD:	4 / 8 KV
EN 61000-4-3 HF radiated:	10 V/m
EN 61000-4-4 Burst:	2 KV
EN 61000-4-5 Surge:	0.5 / 1 KV
EN 61000-4-6 HF conducted:	10 V

UK

1) to EN50178, SELV, PELV

2) in addition PTFE for PN7003...PN7009

3) for PN7000...PN7002, PN7060

4) for PN7003...PN7009

BFSL = Best Fit Straight Line / LS = Limit Value Setting

12.1 Setting ranges

		SP1 / SP2		rP1 / rP2		ΔP
		min	max	min	max	
PN7000	bar	4	400	2	398	2
	PSI	60	5790	30	5760	30
	MPa	0.4	40.0	0.2	39.8	0.2
PN7001	bar	2	250	1	249	1
	PSI	40	3620	20	3600	20
	MPa	0.2	25.0	0.1	24.9	0.1
PN7002	bar	1.0	100.0	0.5	99.5	0.5
	PSI	20	1450	10	1440	10
	MPa	0.10	10.00	0.05	9.95	0.05
PN7003	bar	0.2	25.0	0.1	24.9	0.1
	PSI	4	362	2	360	2
	MPa	0.02	2.50	0.01	2.49	0.01
PN7004	bar	-0.90	10.00	-0.95	9.95	0.05
	PSI	-13	145	-14	144	1
	MPa	-0.090	1.000	-0.095	0.995	0.005
PN7006	bar	0.02	2.50	0.01	2.49	0.01
	PSI	0.4	36.2	0.2	36.0	0.2
	kPa	2	250	1	249	1
PN7007	mbar	10	1000	5	995	5
	PSI	0.2	14.5	0.1	14.4	0.1
	kPa	1.0	100.0	0.5	99.5	0.5
	inHg	0.3	29.5	0.2	29.4	0.1
PN7009	mbar	-970	1000	-980	990	10
	PSI	-14.0	14.4	-14.2	14.2	0.2
	kPa	-97.0	100.0	-98.0	99.0	1.0
	inHg	-28.8	29.4	-29.1	29.1	0.3

ΔP = increments

		SP1 / SP2		rP1 / rP2		ΔP
		min	max	min	max	
PN7060	bar	6	600	3	597	3
	PSI	100	8700	50	8650	50
	MPa	0.6	60.0	0.3	59.7	0.3

ΔP = increments

13 Factory setting

UK

	Factory setting	User setting
SP1	25% VMR*	
rP1	23% VMR*	
OU1	Hno	
OU2	Hno	
SP2	75% VMR*	
rP2	73% VMR*	
dS1	0.0	
dr1	0.0	
dS2	0.0	
dr2	0.0	
P-n	PnP	
dAP	60	
diS	d2	
Uni	bAr / mbAr	

* = the indicated percentage of the final value of the measuring range (VMR) of the corresponding sensor in bar / mbar is set.

More information at www.ifm.com