

- ✓ Various measurement processes
 - ✓ Rapid
 - ✓ Independent of viscosity
 - ✓ Free from losses
- ✓ Plenty of measurement ranges
- ✓ Analogue output signal
- ✓ M12 plug-in connection
- ✓ 24 VDC



The **SensoControl**[®] flow sensors are used for the exact determination of volume flows in hydraulic equipment (eg test and inspection stands). The sensors deliver an output signal proportional to the volume flow for further processing in an electronic system and are compatible with the usual proven industrial standards.





- ✓ M12 plug-in connection
- ✓ 24 VDC
- ✓ 0/4...20 mA

The volume flow can be easily displayed in combination with the SCE-020 built-in measuring instrument.

To meet a multitude of application requirements there are three different measurement principles available:

- ✓ Gear counter SCVF
- ✓ Turbine SCFT
- ✓ Spring/piston SCQ

Volume flow sensors are used in control, regulation and monitoring systems, where analogue signals to capture volume flow are needed.

	SCQ	SCFT	SCVF
Application fields			
	<ul style="list-style-type: none"> ✓ for rapid volume flow changes ✓ measurement in both directions 	<ul style="list-style-type: none"> ✓ low loss volume flow measurement 	<ul style="list-style-type: none"> ✓ measure various media ✓ measure low volume flows (leakage measurement)
	<ul style="list-style-type: none"> ✓ response time ≤ 2 ms ✓ reverse operation ✓ wide viscosity range ✓ compact ✓ up to 420 bar 	<ul style="list-style-type: none"> ✓ response time ≤ 50 ms ✓ many measurement ranges ✓ small flow resistance ✓ up to 800 l/min ✓ up to 420 bar 	<ul style="list-style-type: none"> ✓ very wide measurement range ✓ independent of viscosity ✓ up to 400 bar
Measurement range	SCQ-060: -60 ...+ 60 l/min SCQ-150: -150...+150 l/min	1,0...15/7,5...60/7,5...150/ 15...300/25...600/25...800 l/min	0...2/0...4/0,2...15/0,4...40/0,4...60/ 0,4...80/0,6...150/1...300 l/min
Connection to medium	cartridge M24 block SCAQ-xxx	G1/2...G 1 1/4 BSPP	flange & BSPP
Measurement method	spring/piston	turbine	volume/gear counter
Accuracy	< ± 2 % FS response speed ≤ 2 ms	< ± 1 % FS response speed ≤ 50 ms	< ± 0,5 % FS response speed ≤ 400 ms
Electrical connection	M12x1; 4-pole	M12x1; 4-pole	M12x1; 4-pole
Electrical output	0...20 mA = -60 ...+ 60 l/min 0...20 mA = -150...+150 l/min	4...20 mA; 2-core	0...20 mA
Applications	from inspection stands and general machinery construction through to hydraulic plant construction 		
Order codes	SCQ-xxx-10-07	SCFT-xxx-32-07	SCVF-xxx-10-07
See pages	20-23	24-27	28-33

2.1 SCQ Flow meter

- ✓ **Measurement principle: spring/piston**
- ✓ **Response time ≤ 2 ms**
- ✓ **Measurement in both directions**
- ✓ **Wide viscosity range**
- ✓ **Compact construction**
- ✓ **Pressure resistant up to 420 bar**

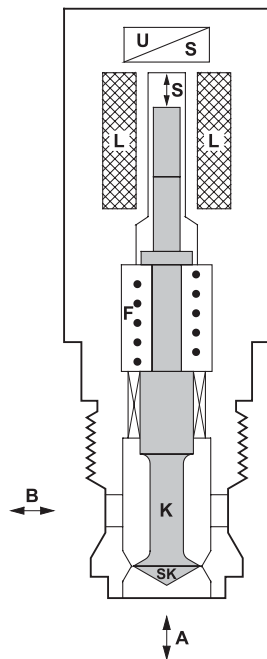

SCQ measurement principle

Function

The piston (K) is moved by flow from A to B or B to A. In idle mode, the spring (F) and piston (K) are in equilibrium. The change in travel (S) is proportional to the volume flow and is converted into a measured value by the built-in electronics. If the direction of flow changes (B to A), flow directions can be displayed (eg -45.8 l/min). The reaction time of the piston movement is smaller than 0.002 s.

Application

The rapid capture of the flow quantity is of great importance in the field of high-pressure hydraulics.

Mounting with the connection block permits a combined measurement of p, T and Q. With the in-line adaptor for tube or hose mounting, rapid installation of the SCQ into the hydraulics is achieved. The rugged construction enables use to continue even under extreme conditions, as for example, high load reversals or pressure increase speeds.

If highly dynamic volume flow changes are to be captured, the SCQ is the ideal solution. Rapid load changes, which can cause damage to valves or pumps, can be safely captured. Because of its unique measuring process, the SCQ is also in a position to capture volume flows in both directions.

	SCQ-060	SCQ-150
measurement range Q_N	-60...+60 l/min	-150...+150 l/min
Q_{max}	-66...+66 l/min	-165...+165 l/min
media connection	M24 (NG10)	M42 (NG16)
weight (g)	670	1050

Accuracy	
characteristic curve deviation	$\pm 2\%$ FS @ 46cSt.
response time	2 ms
thermal drift	$\pm 0,05\%$ FS/°C
repeat accuracy	$\pm 0,5\%$ FS
Pressure resistance	
pressure range	3...420 bar
working pressure P_N	315 bar
overload pressure P_{max}	420 bar
pressure drop ΔP (bar) @ (FS)	see diagrams
Material	
housing	steel
sealing	NBR
parts in contact with media	steel, NBR
Environmental conditions	
working temperature	+10...+60 °C
storage temperature	-20...80 °C
Tmax fluid	+80 °C
filtration	25 μ m
viscosity range	15...100 cSt.
protection class	IP67 DIN EN 60529
Electrical connections	
plug-in connector	M12x1; 4-pole
supply voltage	+18...+30 VDC
current consumption	40 mA
output	0...20 mA = -FS...+FS (10 mA = 0 l/min)
working resistance	$\leq 150\ \Omega$
signal noise	< 5 mV
EM compatibility	
interference emissions	EN 61000-6-3
interference resistance	EN 61000-6-2

Pin designation
M12 plug-in connection

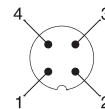

PIN	0...20 mA 3-wire
1	+U _b
2	Q signal
3	0 V/GND
4	-

SCQ-060 screw-in hole and pressure drop curve

Tightening torque 20 Nm

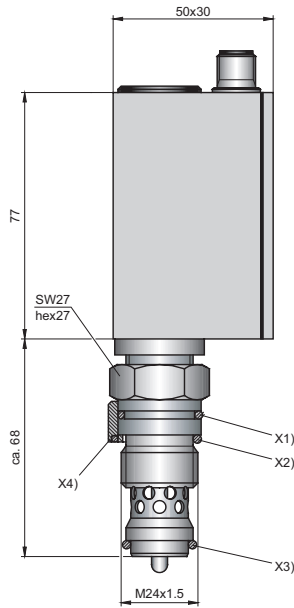

- x1) O-ring 21,95x1,78
- x2) O-ring 20,29x2,2
- x3) O-ring 15,54x2,62
- x4) C-ring

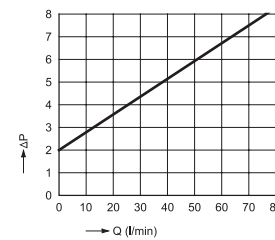
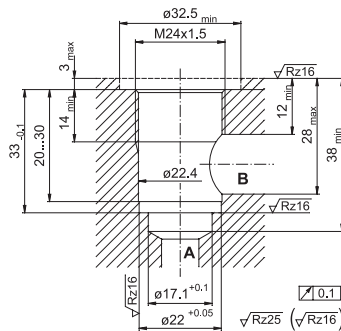

SCQ-150 screw-in hole and pressure drop curve

Tightening torque 30 Nm

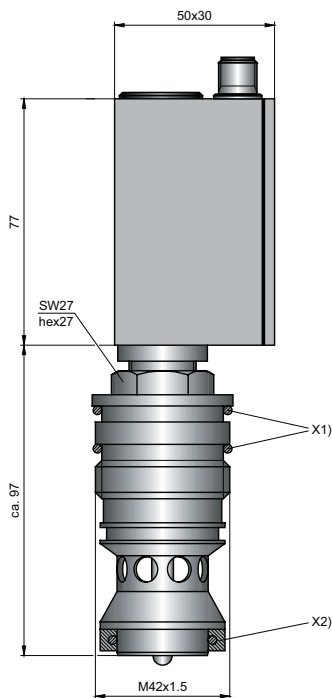

- x1) O-ring 36,17x2,62
- x2) PTFE with O-ring 2,64x2,62

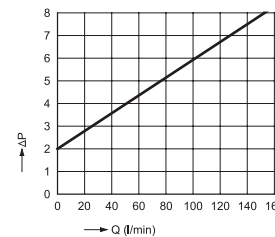
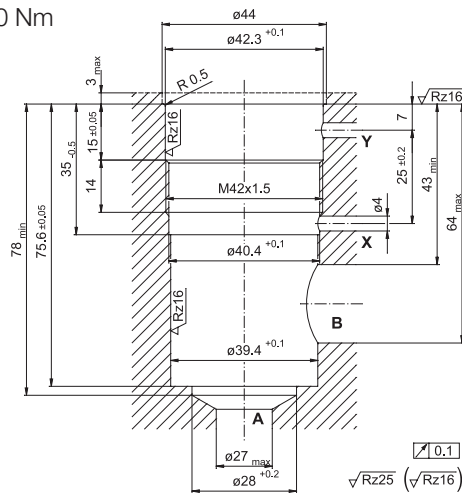

SCAQ-060

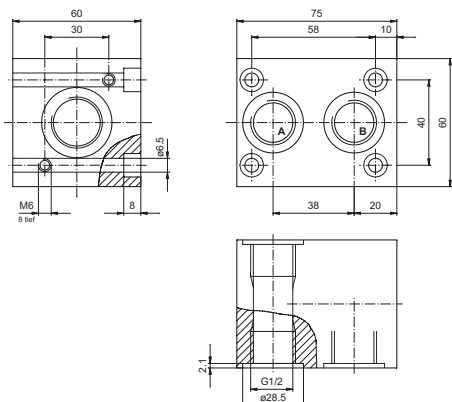

SCAQ-GI-R1/2

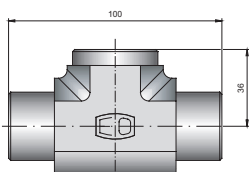

SCAQ-150

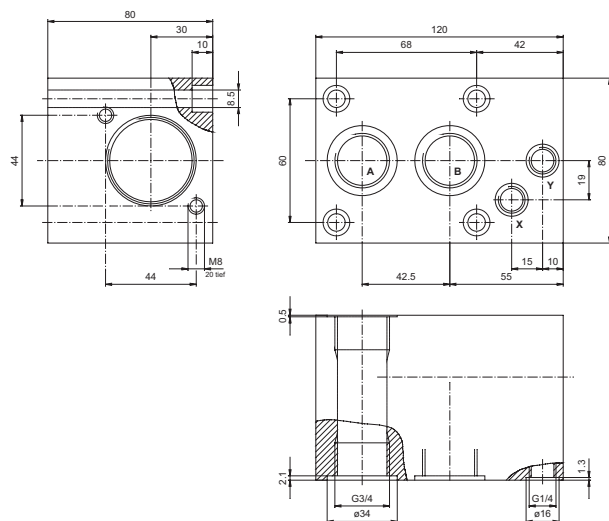

Order codes

SCQ-060 (-60...+60 l/min)

SCQ-060-10-07

M12x1, 4-pole; plug-in connector; IP67
0...20 mA; -60...+60 l/min (incl. distance ring)

SCQ-060 accessories:

in-line adaptor
G1/2 BSPP internal (A-B) und M24 internal
with locking screw:
M24 external (SCQ-M24X1,5-ED)

SCAQ-GIR1/2A4CX

connection block
G1/2 BSPP internal (A-B) and M24 internal
with locking screw:
M24 external (SCQ-M24X1,5-ED)
G1/2 BSPP external (A-B) (SCQ-R1/2-ED)

SCAQ-060

SCQ-150 (-150...+150 l/min)

SCQ-150-10-07

M12x1, 4-pole; plug-in connector; IP67
0...20 mA; -150...+150 l/min

SCQ-150 accessories:

connection block
G3/4 BSPP internal (A-B) and M24 internal
with locking screw
M42 external (SCQ-M42X1,5-ED)
G3/4 BSPP external (A-B) (SCQ-R3/4-ED)

SCAQ-150

Spare parts:

distance ring for SCQ-060
seal set for SCQ-060
seal set for SCQ-150

SC-910

SC-911

SC-912

Connecting cable and Separate plugs

connecting cable, made up

SCK-400-xx-xx

(open cable end)

cable length in m

02 2 m	_____
05 5 m	_____
10 10 m	_____

plug-in connection

45 M12 cable socket; straight	_____
55 M12 cable socket; 90° angled	_____

Separate plugs

M12 cable socket; straight
M12 cable socket; 90° angled

SCK-145

SCK-155

2.2 Messturbine SCFT

- ✓ Measurement principle: turbine
- ✓ Response speed ≤ 50 ms
- ✓ Measurement ranges from 1 to 800 l/min
- ✓ Low flow resistance
- ✓ Nominal pressure to 480 bar
- ✓ Suitable for reverse operation
- ✓ Built-in pressure and temperature connections

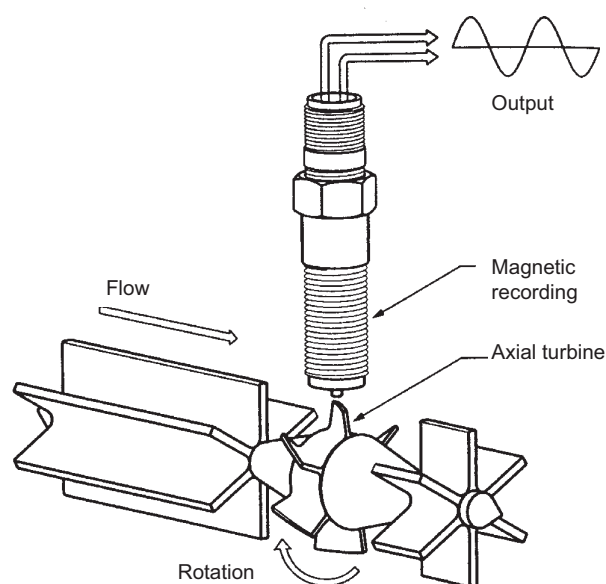

Function

The turbine wheel is driven by the oil flow and starts to turn. The frequencies which this produces are processed by the digital electronics and the influences of interfering flow effects are compensated. Thanks to low flow resistance Q_R , the hydraulic circuit is operated with low losses.

Because of the special vane design, reverse operation is also possible, i.e. the turbine can be operated in both directions.

The turbine is equipped with an EMA-3 screw coupling for measurement of pressure. Oil temperatures can be measured by inserting an SCT-150 directly into the turbine oil stream. In this way all the important measurement parameters are available at one installation location.

Application

If the volume flow is to be captured without loss over wide volume ranges (up to 800 l/min), then the SCFT is the ideal solution.

2.2 SCFT Flow measurement turbine

Technical data & connection designation

	SCFT-015	SCFT-060	SCFT-150	SCFT-300	SCFT-600	SCFT-800
measurement range Q_n (l/min)	1...15	4...60	6...150	10...300	20...600	25...800
accuracy (\pm %) FS/IR @ 21cSt.	\pm 1 % FS	\pm 1 % IR	\pm 1 % IR	\pm 1 % IR	\pm 1 % IR	\pm 1 % IR
working pressure P_n (bar)	420	420	420	420	350	480
connection (A - B)	G1/2 BSPP	G3/4 BSPP	G3/4 BSPP	G1 BSPP	G1 1/4 BSPP	G1 7/8 UNF
pressure drop ΔP (bar) @ (FS)	1,5	1,5	1,5	4	4	5
weight (g)	650	750	750	1200	1800	2100

FS = full scale measurement range
IR = indicated reading

response time (ms)	50
Q_{max} (l/min)	$Q_N \times 1,1$
overload pressure P_{max} (bar)	$P_N \times 1,2$
connections: temperature measurement (SCT-150) pressure (EMA-3 connection) pressure (VSTI)	M10x1 OR M16x2 G1/4 BSPP
housing	aluminium
sealing	FKM
parts in contact with media	aluminium; steel; FKM

environmental temperature (°C)	+10...+60
storage temperature (°C)	-20...+80
T_{max} fluid (°C)	+80
filtration (μ m)	25
viscosity range (cSt.)	15...100

Electrical connections	
connector	M12x1; 4-pole
supply voltage U_b	18...30 V
2-core output signal I_{out}	4...20 mA 0...FS l/min
total output current range	0-21 mA
I_B	< 30 mA

PIN designation
M12 plug-in connector

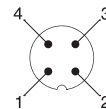

PIN	4...20 mA 2-wire
1	+ U_b
2	Q signal
3	-
4	-

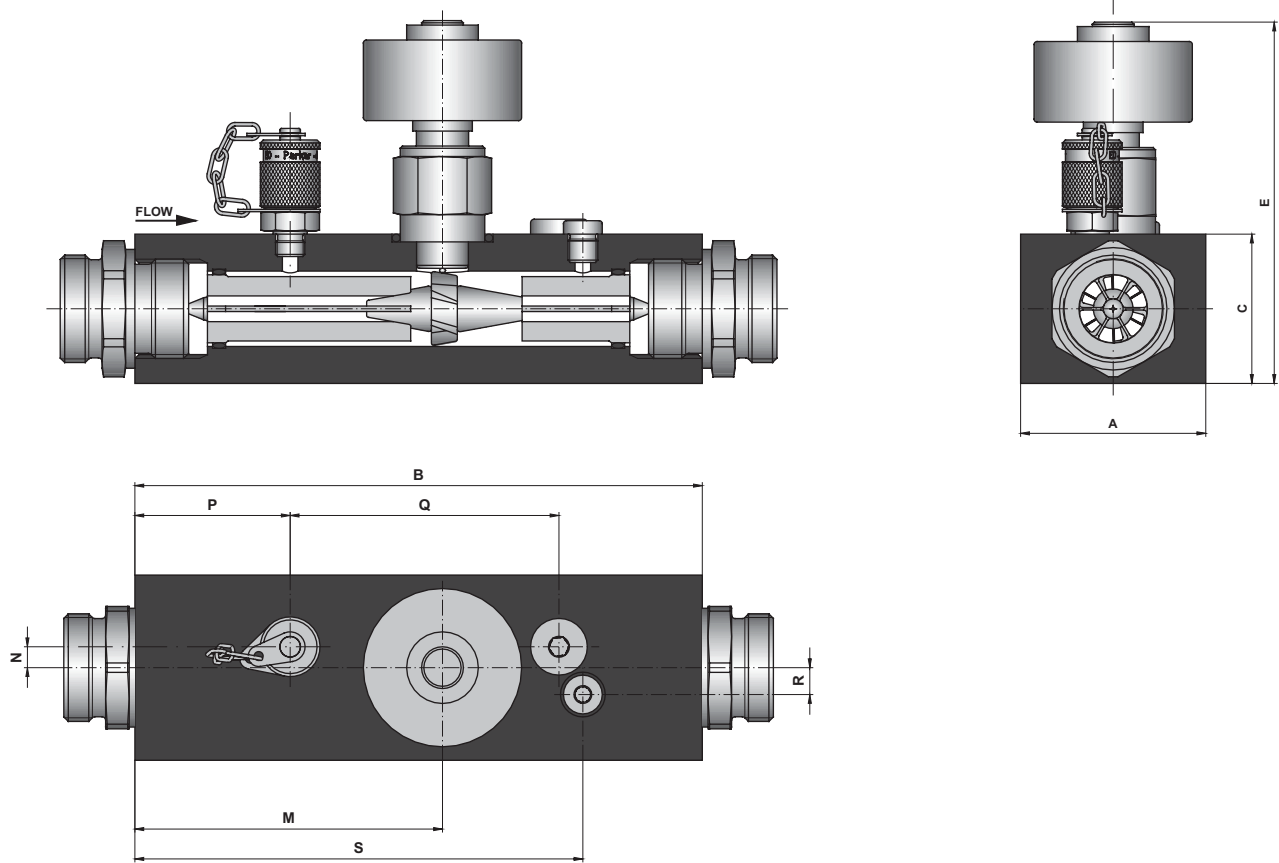

#	SCFT-015	SCFT-060	SCFT-150	SCFT-300	SCFT-600	SCFT-800
A	37	62	62	62	62	100
B	136	190	190	190	212	212
C	37	50	50	50	75	75
E	117	130	130	134	150	154
M	70	103	103	103	127	126
N	0	5	5	7	9	10
P	25	50	50	52	62	60
Q	N/A	92	92	90	106	104
R	0	5	5	9	11	10
S	115	157	157	150	168	181

Order codes**SCFT**

M12x1; 4-pole; plug-in connector; IP67

4...20 mA; 2-core

1...15 l/min

SCFT-015-32-07

4...60 l/min

SCFT-060-32-07

6...150 l/min

SCFT-150-32-07

10...300 l/min

SCFT-300-32-07

20...600 l/min

SCFT-600-32-0725...800 l/min; P_N = 480 bar**SCFT-800-32-07****Connecting cables and separate plugs****connecting cables, made up****SCK-400-xx-xx**

(open cable end)

cable length in m

02 2 m**05** 5 m**10** 10 m

plug-in connector

45 M12 cable socket; straight**55** M12 cable socket; 90° angled**Separate plugs**

M12 cable socket; straight

SCK-145

M12 cable socket; 90° angled

SCK-155

2.3 SCVF Volume counter

- ✓ **Measurement principle:**
gearwheel volume counter
- ✓ **8 measurement ranges**
from 0.01...2 to 1.0...300 l/min
- ✓ **Measurement accuracy $\pm 0,5$ % FS**
- ✓ **Pressure resistant to 400 bar**
- ✓ **High viscosity range**
- ✓ **Low noise**
- ✓ **Exact flow measurement**
over wide viscosity range
- ✓ **Flexible use for various media**



Gearwheel counter for high accuracy flow measurement in hydraulic equipment

Function

The **SCVF** gearwheel counter works as a volume flow counter. A very precisely machined pair of gears is driven by the fluid flow. The **SCVF** works in a wide range of viscosities. Various seals permit a variety of applications.

Applications

Thanks to this wide range of viscosities, all fluids which can be pumped and have a certain degree of lubricating ability can be measured:

- ✓ Brake fluid (EPDM seals)
- ✓ Skydrol
- ✓ Mineral oils
- ✓ Hydraulic oils
- ✓ Greases

If exact flow measurements over a wide range of viscosities are to be captured, the SCVF is the ideal solution.

SCVF	002	004	015	060	080	150	300
measurement range (l/min)	0,01...2,0	0,02...4,0	0,2...15	0,4...60	0,4...80	0,6...150	1,0...300
pressure range P _N (bar)	400	315	400	400	400	315	315
overload pressure P _o (bar)	480	400	480	480	480	350	350
connector	G3/8 BSPP	G3/8 BSPP	G3/8 BSPP	G1/2 BSPP	G1/2 BSPP	G1 BSPP	G1 BSPP
noise level db (A)	< 60	< 60	< 60	< 70	< 70	< 70	< 72
resolution (impulses/litre)	40.000	25.000	4082	965	965	333,33	191
frequency (Hz) @ FS	1333,33	1666,66	1020,5	965	1286,6	833,33	955

Accuracy	
characteristic curve deviation	± 0,5 % FS at 20 cSt.
repeat accuracy	0,01 % FS
response time *)	< 10 ms
medium **)	hydraulic oil (25 µ filter)
Material	
	1.7139 material; non-ferrous metal and silicon-free
housing	GGG 40
sealing	FKM EPDM on request
Environmental conditions	
environmental temperature	0...+55 °C
storage temperature	-25...+85 °C
fluid temperature	-30...120 °C
viscosity range	see diagram p.30
protection class	IP65 DIN EN 60529
Electrical connections	
connector	M12x1; 4-pole
supply voltage U _b	18...30 V
output signal I _{out}	0...20 mA 0...FS l/min
working resistance	< 250 Ω
current consumption I _b	< 28 mA
EM compatibility	
interference emissions	EN 61000-6-3
interference resistance	EN 61000-6-2

Pin designation
M12 plug-in connector

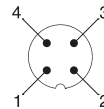

Pin	0...20 mA 3-wire
1	+U _b
2	Q signal
3	0 V/GND
4	-

FS = full scale measurement range

*) in combination with signal converter

**) for applications with other media, please
give viscosity range and type of seals
(attach medium data sheet if applicable)

SCVF-002 Δp - Viscosity

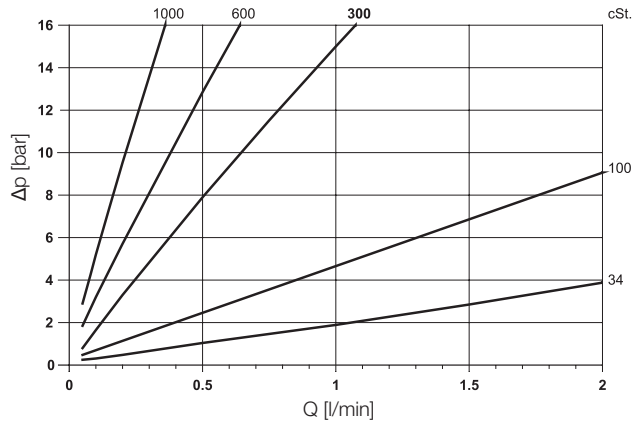

SCVF-004 Δp - Viscosity

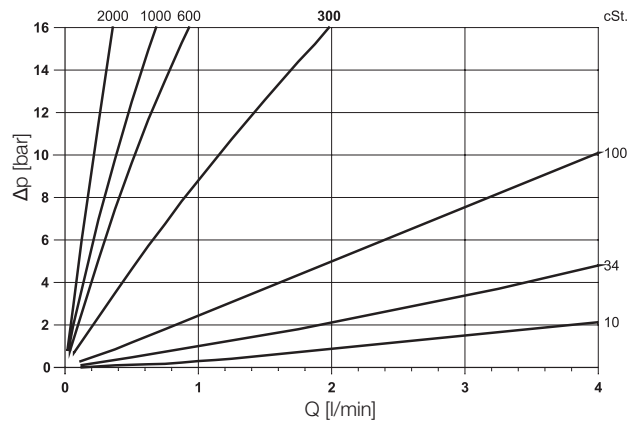

SCVF-015 Δp - Viscosity

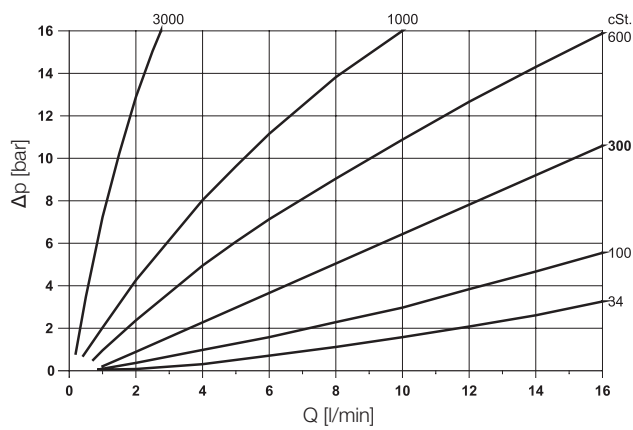

SCVF-040/060/080 Δp - Viscosity

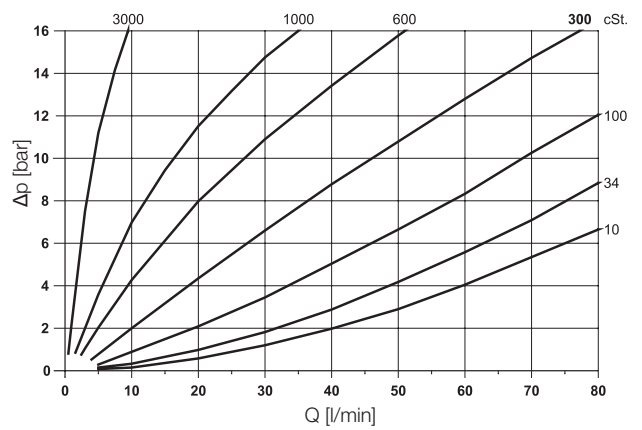

SCVF-150 Δp - Viscosity

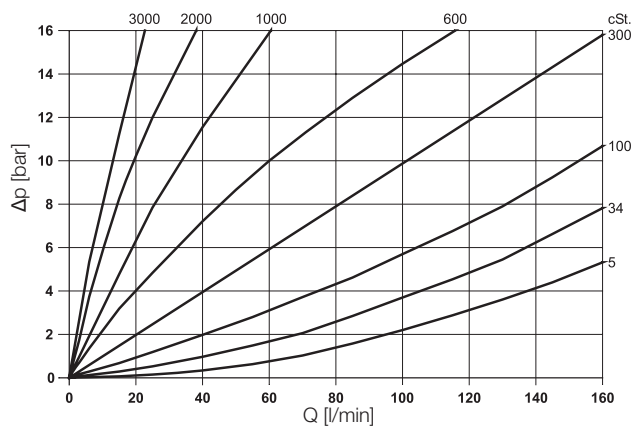

SCVF-300 Δp - Viscosity

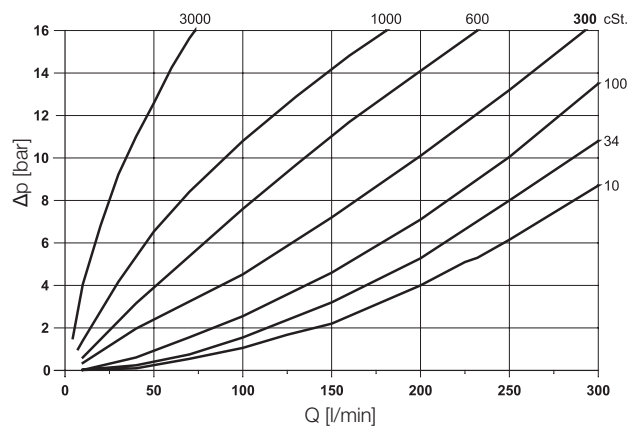

Δp = Pressure drop

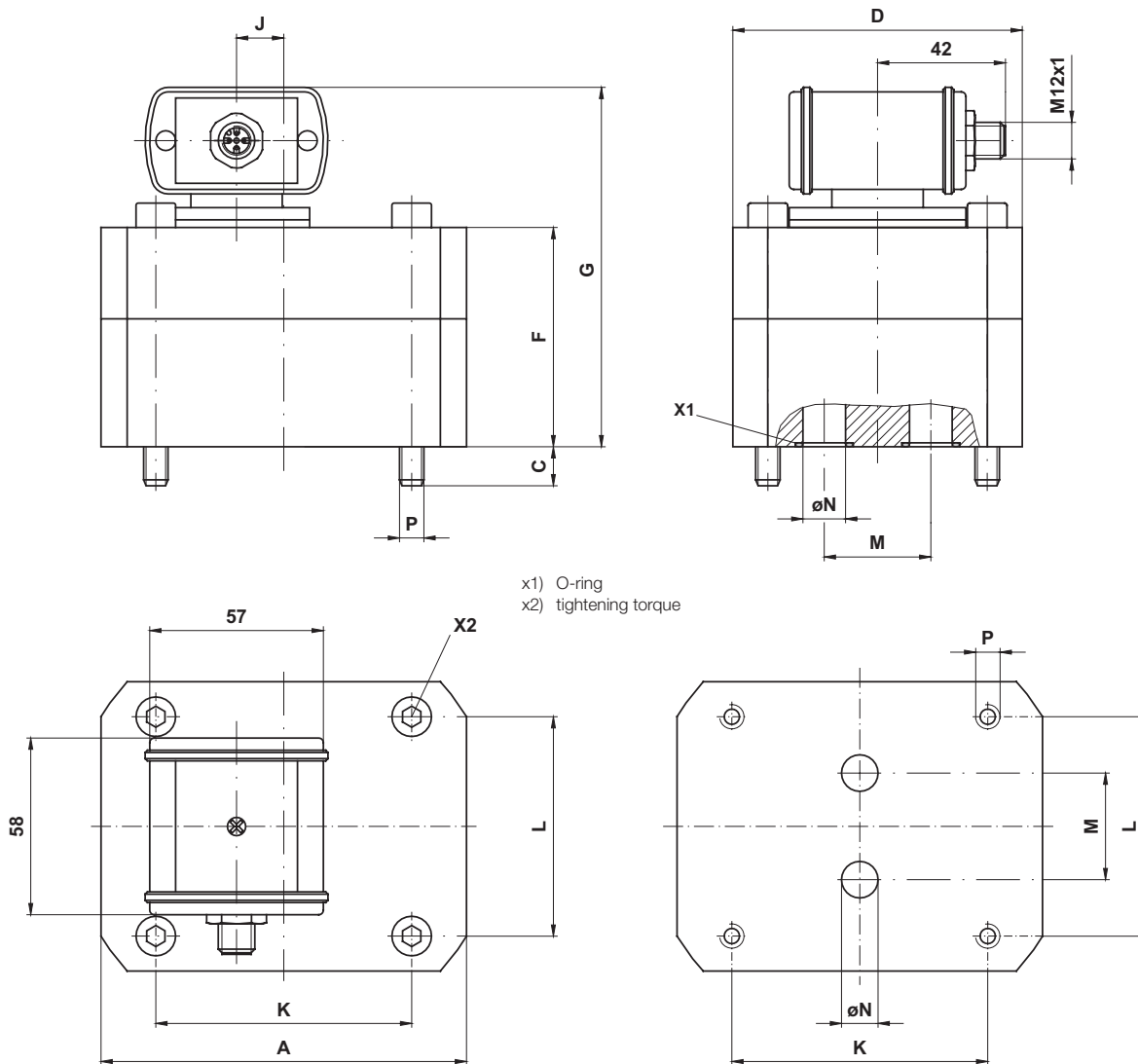

SCVF-004	2	14	85	9	60	56	-	70	40	20	6,5	M6	
SCVF-015	2	14	85	13	60	57	94	-	70	40	20	9	M6
SCVF-040	5,2	35	120	13	95	72	109	10,5	84	72	35	16	M8
SCVF-060													
SCVF-080													
SCVF-150	9	120	170	18	120	89	140	46,5	46	95	50	25	M12
SCVF-300	13	120	170	22	120	105	142	40	46	95	50	25	M12

all dimensions in mm

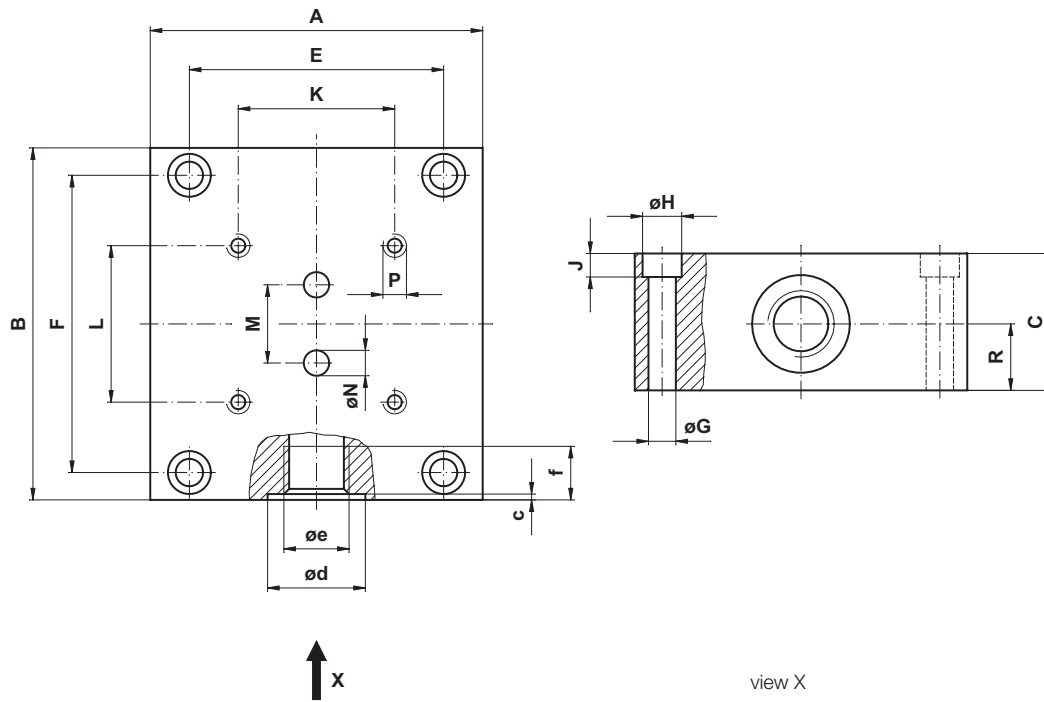

Type	kg	A	B	C	E	F	øG	øH	J	K	L	M	øN	P	R	c	ød	øe BSPP	f
SCVF-002 SCVF-004 SCVF-015	1,8	85	90	35	65	76	7	11	7	70	40	20	6,5	M6/t = 14	17	0,7	25	G3/8	13
SCVF-040 SCVF-060 SCVF-080	2,9	100	120	37	80	106	7	11	7	84	72	35	12	M8/t = 18	17,5	0,7	29	G1/2	15
SCVF-150 SCVF-300	14	160	165	80	140	145	9	15	9	46	95	50	25	M12/t = 24	28	1	42	G1	19

all dimensions in mm

Order codes**SCVF**

M12x1; 4-pole; plug-in connector; IP67

0...20 mA

0,01...2 l/min

SCVF-002-10-07

0,02...4 l/min

SCVF-004-10-07

0,2...15 l/min

SCVF-015-10-07

0,4...40 l/min

SCVF-040-10-07

0,4...60 l/min

SCVF-060-10-07

0,4...80 l/min

SCVF-080-10-07

0,6...150 l/min

SCVF-150-10-07

1...300 l/min

SCVF-300-10-07**Connecting cables and Separate plugs****connection cable, made up****SCK-400-xx-xx**

(open cable end)

cable length in m

02 2 m**05** 5 m**10** 10 m

plug-in connector

45 M12 cable socket; straight**55** M12 cable socket; 90° angled**Separate plugs**

M12 cable socket; straight

SCK-145

M12 cable socket; 90° angled

SCK-155

6 Determination of Flow Volume

Depending on the measurement job to be done, various measuring instruments are available to the hydraulic technician:

1 Flow meter type SCQ

- Flow measurement with direction indication
- Very fast reaction time < 2 ms
- Wide viscosity range
- Screw-in cartridge in connector block SCAQ

2 Turbine flow meter type SCFT

- Very low flow resistance
- Built-in measurement points for pressure and temperature
- Very simple installation into a hydraulic system
- 6 different measuring ranges up to 750 l/min.
- Recording of a p/Q characteristic curve with a load valve to determine hydraulic performance

3 Gear flow meter type SCVF

- High precision flow measurement over a wide range of viscosity
- 4 measuring ranges up to 300 l/min.
- flexible use with various fluids



In addition to pressure measurement, the precise determination of flow volume in hydraulic equipment gives important evidence of the condition of the hydraulics. The efficiency of hydraulic drives such as hydrostatic units or variable pumps depends on the amount of flow. Hydraulic performance is determined by pressure and flow. The degree of wear in a hydraulic drive can be ascertained by comparing nominal and actual values. The resulting measurements can be used, for example, in preventive maintenance for systematic servicing and cost reductions. In mobile hydraulics, the efficiency of the machine is continually checked and documented. The diagnosis of pressure and flow thereby gives a total analysis.

- Measurement principle: spring/piston system
- Flow measurement with direction indication
- Response time < 2 ms
- Compact design
- Withstands pressures up to 420 bar
- Wide range of viscosity
- p/T/Q measurement possible with connection block

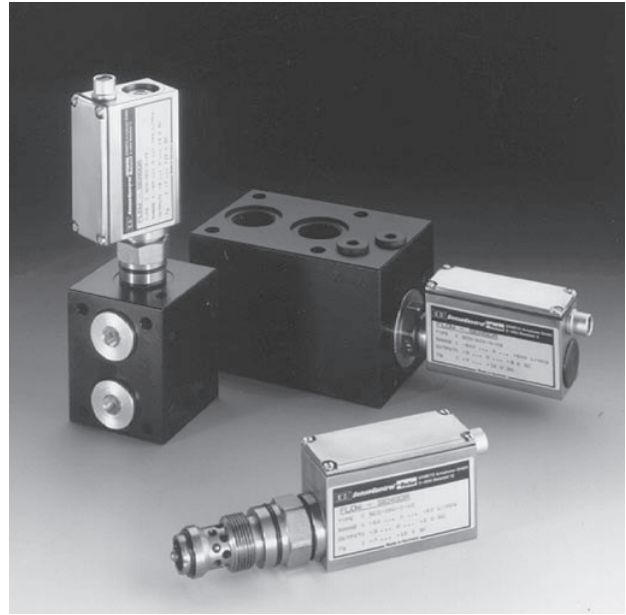

Flow measurement with direction indication for mobile and stationary measurement jobs

Function

When there is a flow from A to B or B to A, the piston (K) is moved. When at rest, the spring (F) and piston (K) are in equilibrium. The stroke change (S) is proportional to the flow volume and is converted by the built-in electronics to a measured value. By the change in direction of the piston (B to A) flow directions can be shown (e.g. -45.8 l/min.). The response time of the piston movement is less than 0.002 s.

Application

In the field of high pressure hydraulics, the rapid capture of the amount of flow is of great significance. The reaction times of the SCQ's enable the dynamic behaviour of hydraulic systems to be measured. The indication of direction is helpful when searching for faults in hydraulic systems. Rapid load changes, which can cause damage for example in valves and pumps, can be determined. Installation with a connection block permits the combined measurement of p, T and Q. Rapid assembly of the SCQ's is achieved with an in-line adaptor for tube or hose installation.

Robust design makes possible extreme condition applications, such as, for example, high load changes or rates of pressure increase.

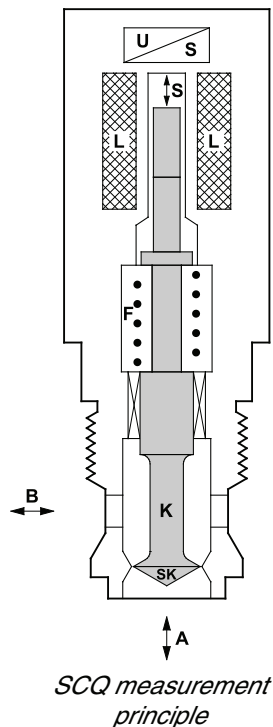

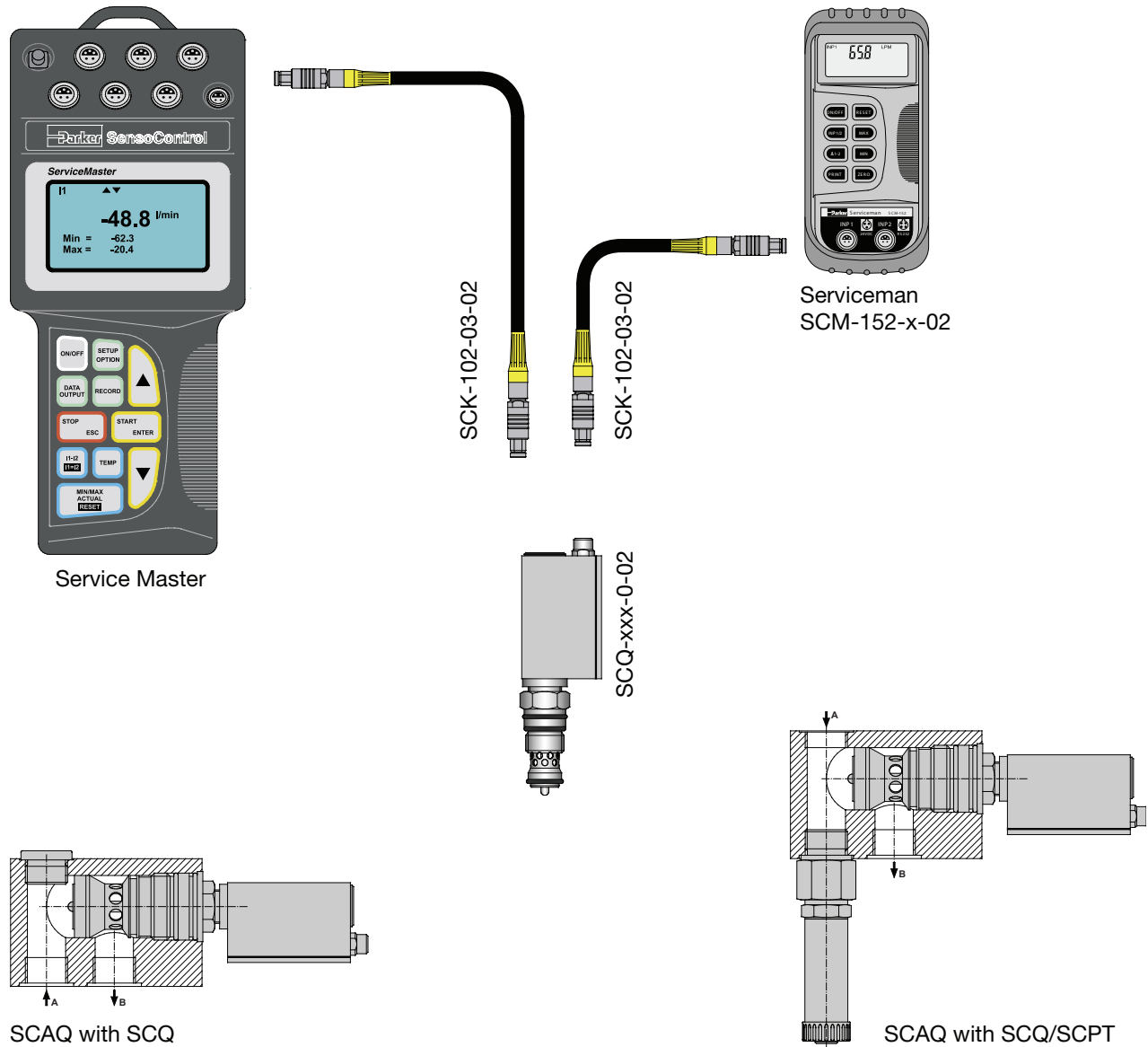

SCQ	#
0...60 l/min	SCQ-060-0-02
0...150 l/min	SCQ-150-0-02
(flow direction indication with Service Master only)	

Connection Cables	#
Serviceman (4 pin) 2 m	SCK-102-02-08
Serviceman/Service Master (5 pin) 3 m	SCK-102-03-02
Extension 5 m	SCK-102-05-12

#	SCQ-060	SCQ-150
Flow Range QN (l/min)	-60...+60	-150...+150
Accuracy (± %) FS @ 46cSt.	2,0	2,0
Operating Pressure PN (bar)	315	315
Ports	M24 (NG10)	M42 (NG16)
Pressure Drop P _{max} (bar) @ (FS)	Graphs	
Weight (g)	670	1050

FS = FullScale

Response Time (ms)	2
Q _{max} (l/min)	QN x 1,1
Overload Pressure P _{max} (bar)	420
Housing	Steel
Sealing	NBR
Parts in Contact with Media	Steel, NBR

Ambient Temperature (°C)	+10...+60
Storage Temperature (°C)	-20...+80
T _{max} Fluid (°C)	+80
Filtration (µm)	25
Viscosity Range (cSt.)	15...100

#	SCAQ-GI-R-1/2	SCAQ-060	SCAQ-150
Ports (SCQ)	M24 (NG10)	M24 (NG10)	M42 (NG16)
Ports (A - B)	1/2" BSPP	1/2" BSPP	3/4" BSPP

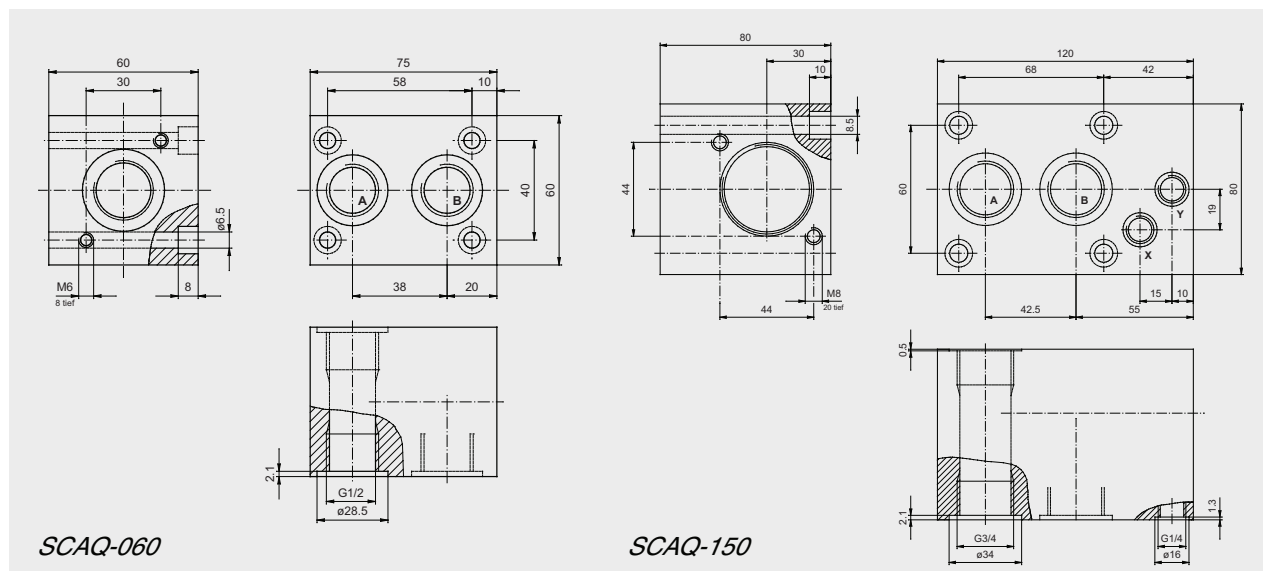

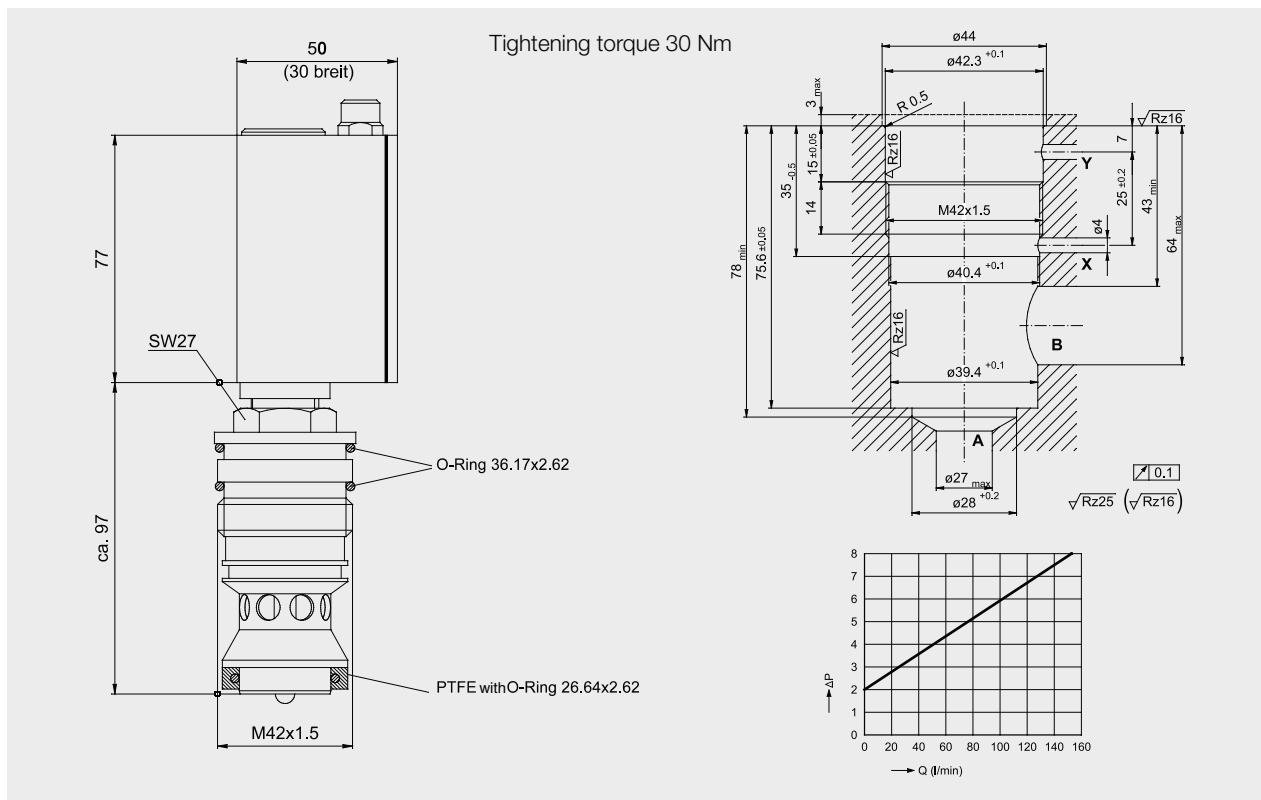
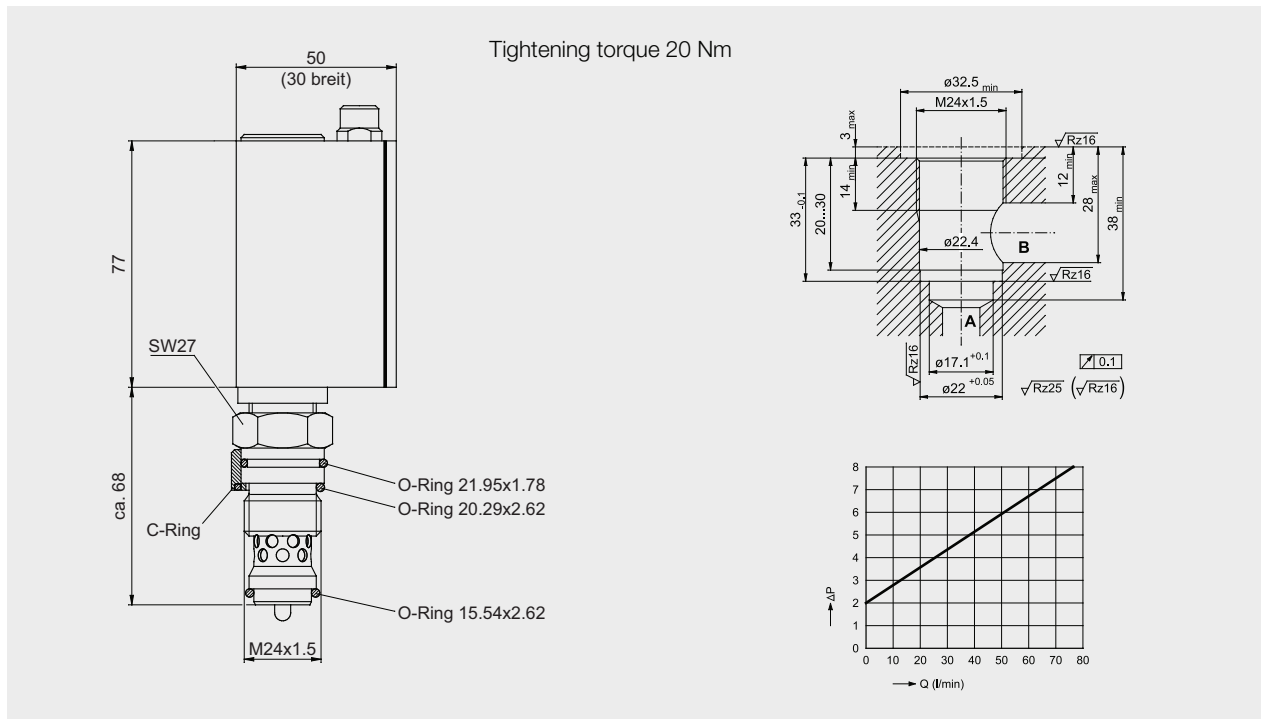

- Measurement principle:
flow turbine
- 6 flow ranges up to 750 l/min
- Simple installation
- Resistant to high pressure
up to 480 bar
- Low flow resistance
- Built-in pressure and temperature
measurement points
- Suitable for reverse operation



Flow measurement with low flow resistance combined p/T/Q measurement

Function

A turbine wheel is driven by the oil flow. The frequencies thus produced are processed by digital electronics. The influence of turbulent flow effects is compensated for.

Because of the low flow resistance Q_R the hydraulic circuit operates with very low losses. For pressure measurement the turbine is equipped with an EMA-3 test point.

Oil temperatures are measured direct in the oil flow. Consequently all the important measurement parameters are available at one measuring location.

Applications

- mobile diagnosis (SCFT with SCM)
- p-Q measurement in construction and agricultural machines
- hydraulic tests with load valves
- automatic scaling

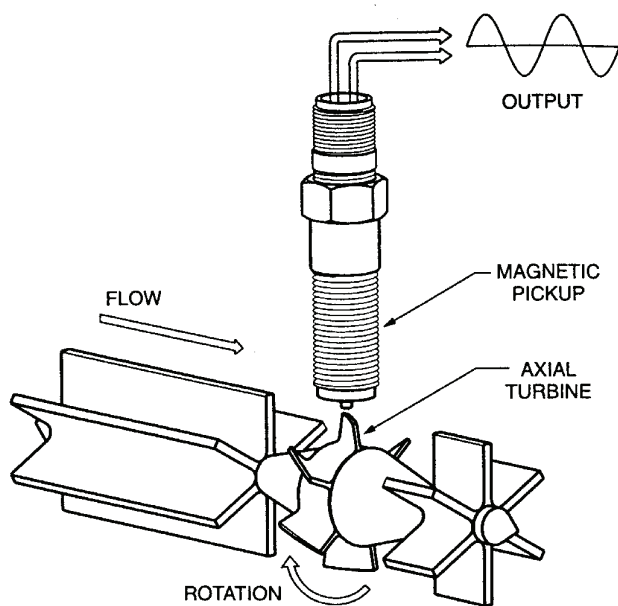

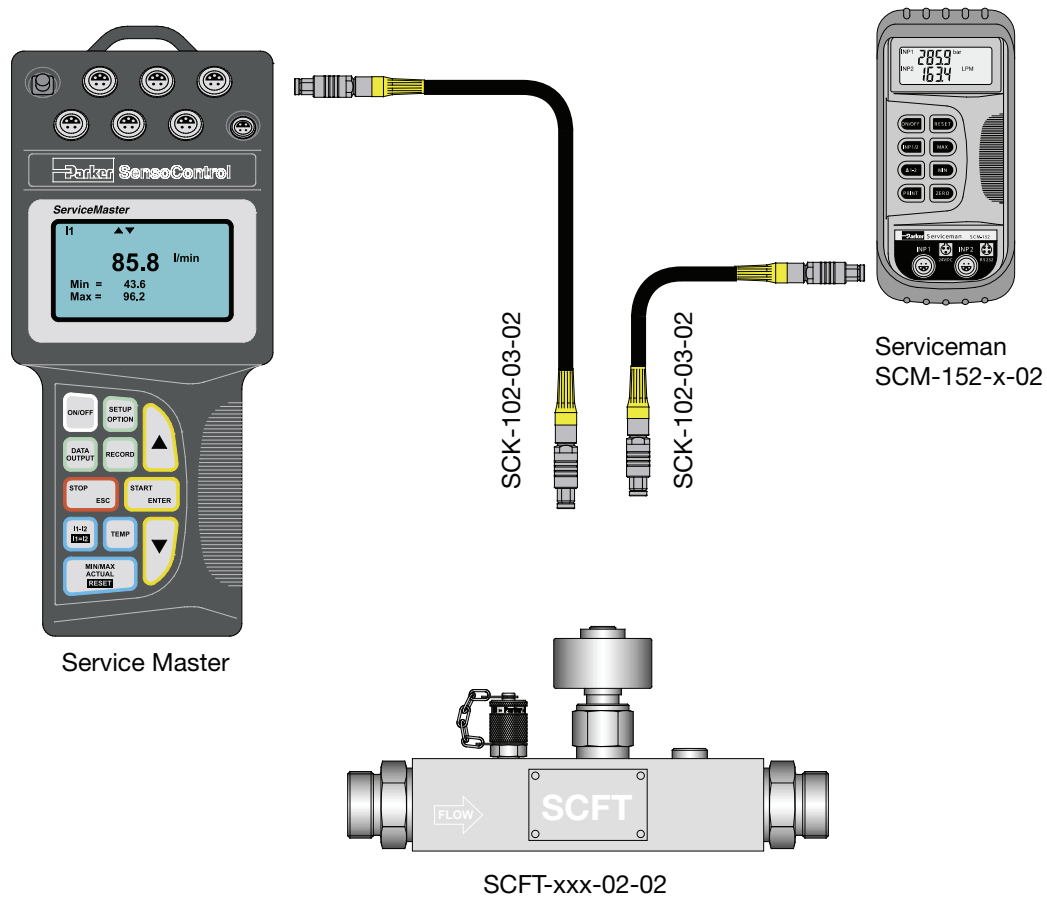

SCFT Serviceman/Service Master	#
1 ... 015 l/min	SCFT-015-02-02
4 ... 060 l/min	SCFT-060-02-02
6 ... 150 l/min	SCFT-150-02-02
10 ... 300 l/min	SCFT-300-02-02
20 ... 600 l/min	SCFT-600-02-02
25 ... 750 l/min	SCFT-750-02-02

Connection Cables	#
Serviceman (4 pin) 2 m	SCK-102-02-08
Serviceman/Service Master (5 pin) 3 m	SCK-102-03-02
Extension 5 m	SCK-102-05-12

6.2 Determination of Flow Volume

Turbine Flow Meter

#	SCFT-015	SCFT-060	SCFT-150	SCFT-300	SCFT-600	SCFT-750
Flow Range QN (l/min)	1...015	4...060	6...150	10...300	20...600	25...750
Accuracy (± %) FS/IR @ 21 cSt.	1,0 FS	1,0 IR	1,0 IR	1,0 IR	1,0 IR	1,0 IR
Operating Pressure PN (bar)	420	420	420	420	350	480
Ports (A - B)	1/2" BSPP	3/4" BSPP	3/4" BSPP	1" BSPP	1-1/4" BSPP	1-7/8" UNF
Pressure Drop ΔP_{max} (bar) @ (FS)	1,5	1,5	1,5	4	4	5
Weight (g)	650	750	750	1200	1800	2100

FS = FullScale

IR = Indicated Reading

Response Time (ms)	50
Q_{max} (l/min)	QN x 1,1
Overload Pressure P_{max} (bar)	PN x 1,2
Ports: Temperature Port (SCT-150) Pressure Port (EMA3 Fitting) Pressure Port (VSTI)	M10x1 OR M16x2 1/4" BSPP
Housing	Aluminium
Sealing	Viton® (FKM)
Parts in Contact with Media	Aluminium, Steel, Viton® (FKM)

Ambient Temperature (°C)	+10...+60
Storage Temperature (°C)	-20...+80
T_{max} Fluid (°C)	+80
Filtration (µm)	25
Viscosity Range (cSt.)	15...100

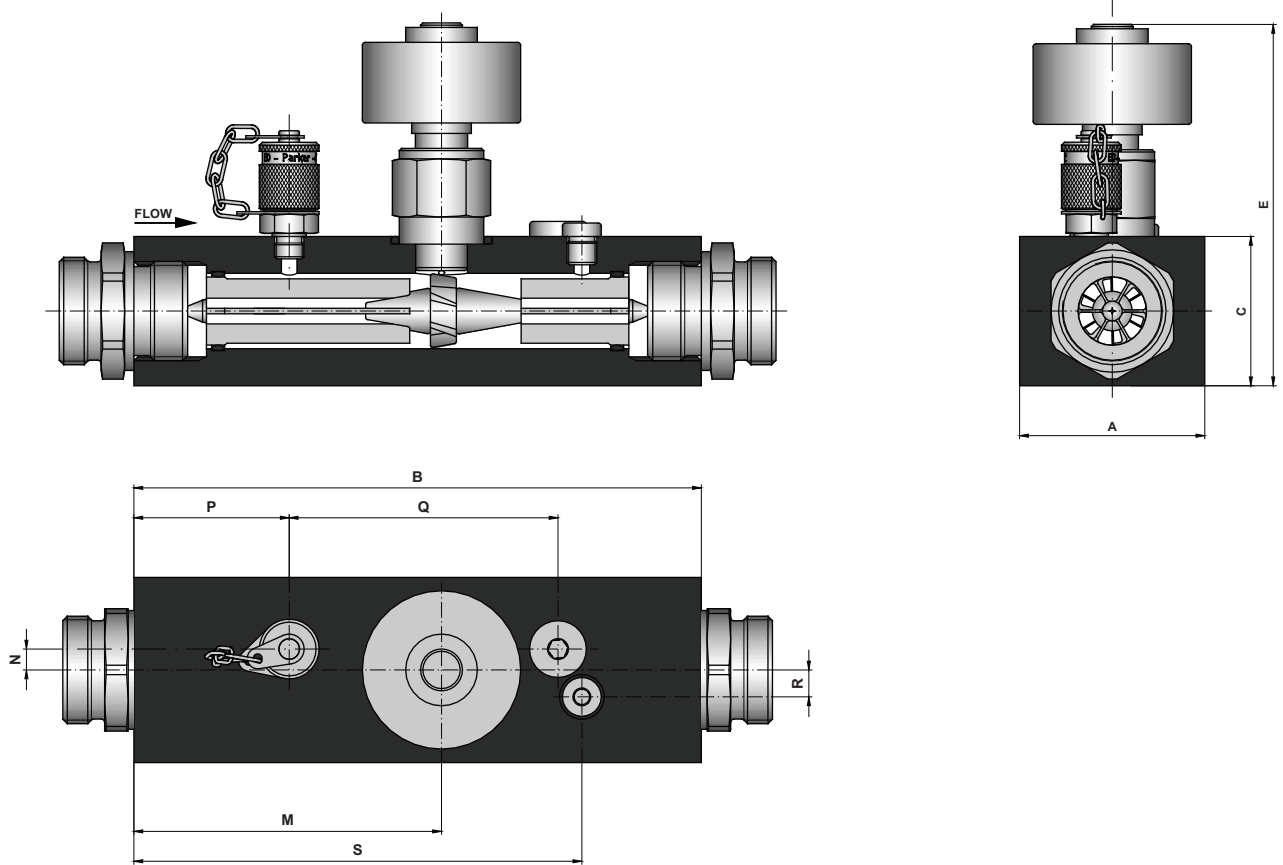

#	SCFT-015	SCFT-060	SCFT-150	SCFT-300	SCFT-600	SCFT-750
A	37	62	62	62	62	100
B	136	190	190	190	212	212
C	37	50	50	50	75	75
E	117	130	130	134	150	154
M	70	103	103	103	127	126
N	0	5	5	7	9	10
P	25	50	50	52	62	60
Q	N/A	92	92	90	106	104
R	0	5	5	9	11	10
S	115	157	157	150	168	181

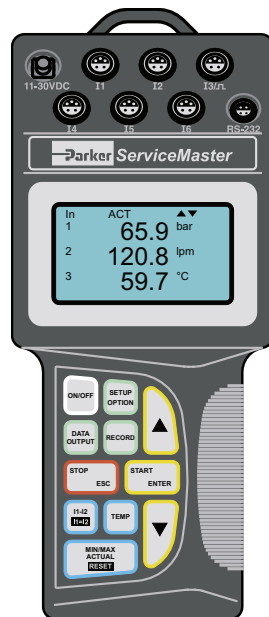
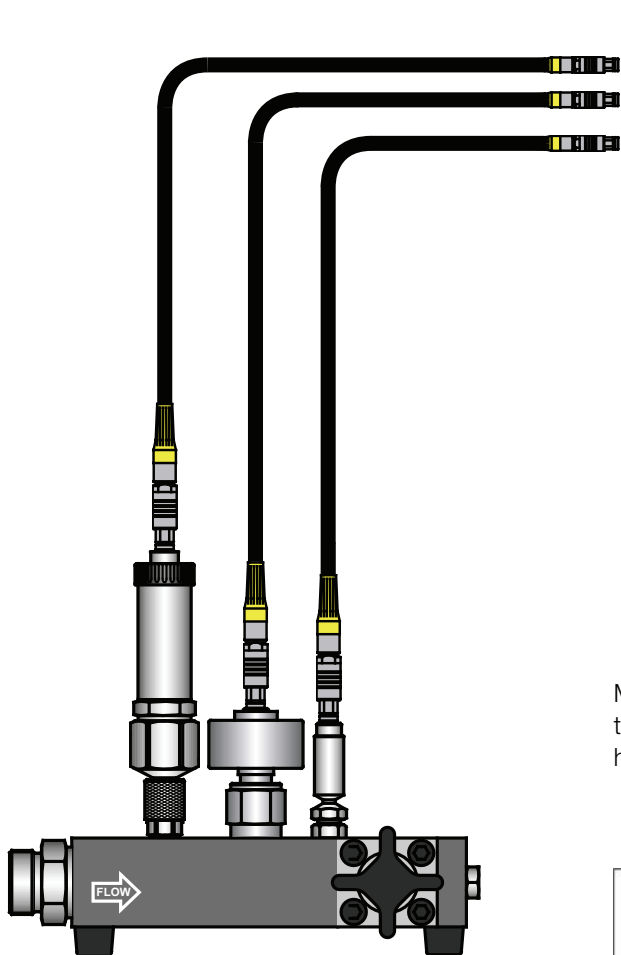

Measurement of pressure, flow and temperature using Service Master and hydraulic-tester SCLV-PTQ

The p-Q diagram (to the right) shows the power determined. Especially in hydraulic pump (load sensing) systems the speed-dependent load is important to analyze. The evaluation in **SensoWin®** will be done quickly and simply.

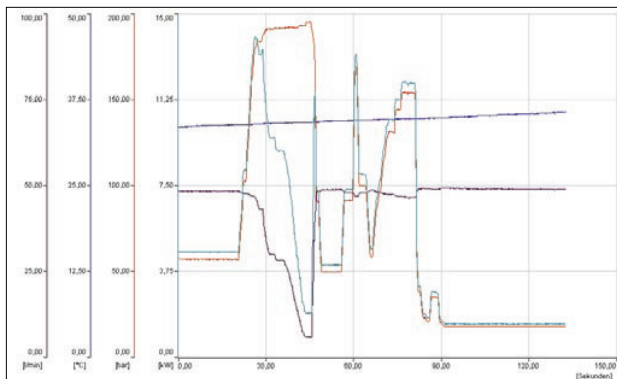
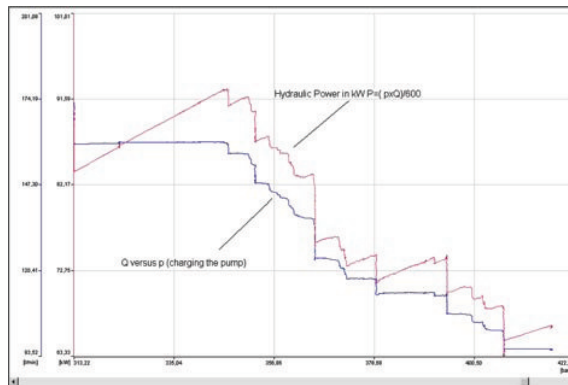

The hydraulic power of a system can be analyzed by a combined measurement of pressure and flow (to the left). The diagram shows an application with a hydraulic-tester SCLV-PTQ. Pressure in the system is generated by the integrated loading valve.

In the evaluation power will be calculated from the flow volume and pressure of the pump.

6.2 Determination of Flow Volume

Hydraulic Tester

#	SCFT-150-DRV	SCLV-PTQ-300	SCLV-PTQ-600	SCLV-PTQ-750
Flow Range QN (l/min)	6...150	10...300	20...600	25...750
Accuracy (\pm %) IR @ 21cSt.	1,0	1,0	1,0	1,0
Operating Pressure PN (bar)	420	420	420	480
Ports (A - B)	3/4" BSPP	1" BSPP	1-7/8" UNF	1-7/8" UNF
Pressure Drop P_{max} (bar) @ (FS)	15	4	5	5
Weight (kg)	4,2	5,5	8,9	8,9

FS = FullScale

IR = Indicated Reading

Response Time (ms)	50
Q_{max} (l/min)	QN x 1,1
Overload Pressure P_{max} (bar)	PN x 1,2
Ports: Temperature Port (SCT-150) Pressure Port (EMA3 Fitting) Pressure Port (VSTI)	M10x1 OR M16x2 1/4" BSPP
Housing	Aluminium
Sealing	Viton® (FKM)
Parts in Contact with Media	Aluminium, Steel, Viton® (FKM)

Ambient Temperature (°C)	+10...+50
Storage Temperature (°C)	-20...+80
T_{max} Fluid (°C)	+110
Filtration (μ m)	25
Viscosity Range (cSt.)	10...90

SCLV-PTQ-xxx

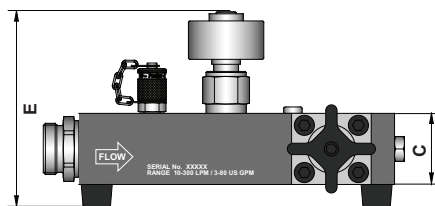

SCFT-150-DRV

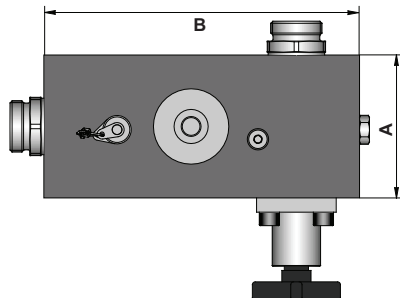
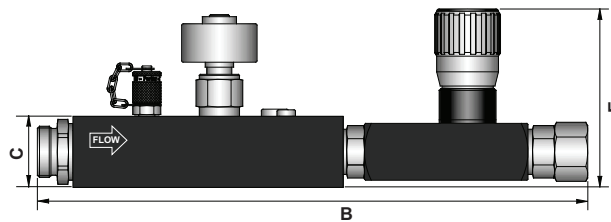

#	SCLV-PTQ-300	SCLV-PTQ-600 SCLV-PTQ-750	SCFT-150-DRV
A	98	117	62
B	222	235	370
C	50	75	50
E	135	150	130

- **Measurement principle:**
volume counter/positive displacement
- **4 flow ranges up to 300 l/min**
- **Measurement accuracy $\pm 0.5\%$ FS**
- **Withstands pressures up to 400 bar**
- **High viscosity range**
- **Low noise emission**



Gear flow for the precision measurement of flow in hydraulic equipment

Function

The **SCVF** gear flow meter operates as a flow volume counter. A very precisely machined pair of gears is driven by the fluid flow.

The **SCVF** accommodates a wide range of viscosity. Various seals* permit a large number of applications.

Applications

Because of the wide viscosity range, all fluids which can be pumped and have a certain lubricating capability can be measured.

- brake fluids (EPDM Sealing)
- Skydrol
- mineral oils
- hydraulic oils
- fats
- mobile diagnosis (SCVF with SCM)
exact Q measurement (oil leakage)
automatic scaling (sensor recognition)

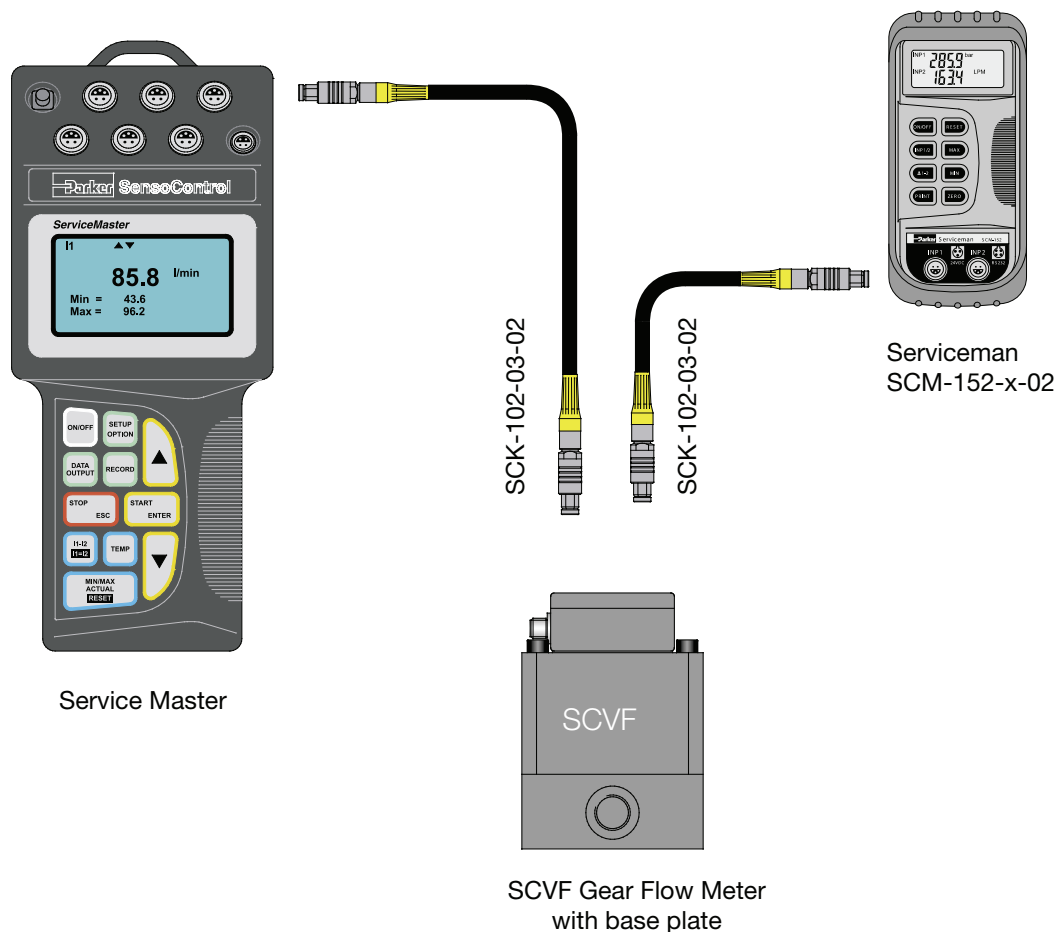

SCVF Serviceman/Service Master	#
0,1 ... 015 l/min	SCVF-015-00-02
0,4 ... 060 l/min	SCVF-060-00-02
0,4 ... 150 l/min	SCVF-150-00-02
1,0 ... 300 l/min	SCVF-300-00-02

Connection Cables	#
Serviceman (4 pin) 2 m	SCK-102-02-08
Serviceman/Service Master (5 pin) 3 m	SCK-102-03-02
Extension 5 m	SCK-102-05-12

6.3 Determination of Flow Volume

Gear Flow Meter

Typ	SCVF-015	SCVF-060	SCVF-150	SCVF-300
Flow Range QN (l/min)	1...015	0,4...060	0,6...150	1...300
Accuracy (± %) FS @ 21cSt.	0,5	0,5	0,5	0,5
Operating Pressure PN (bar)	400	400	315	315
Ports (A - B)	3/8" BSPP	1/2" BSPP	1" BSPP	1" BSPP
Pressure Drop ΔP_{max} (bar) @ (FS)	Graph			
Weight (kg)	3,8	8,1	23	27

FS = FullScale) IR = Indicated Reading

Response Time (ms)	400
Q_{max} (l/min)	QN x 1,1
Overload Pressure P_{max} (bar)	PN x 1,2
Housing	GGG 40
Sealing	Viton® (FKM)
Parts in contact with media	Viton® (FKM), Steel, GGG 40

Ambient Temperature (°C)	+10...+50
Storage Temperature (°C)	-20...+80
T_{max} Fluid (°C)	+110
Filtration (µm)	25
Viscosity Range (cSt.)	Graph

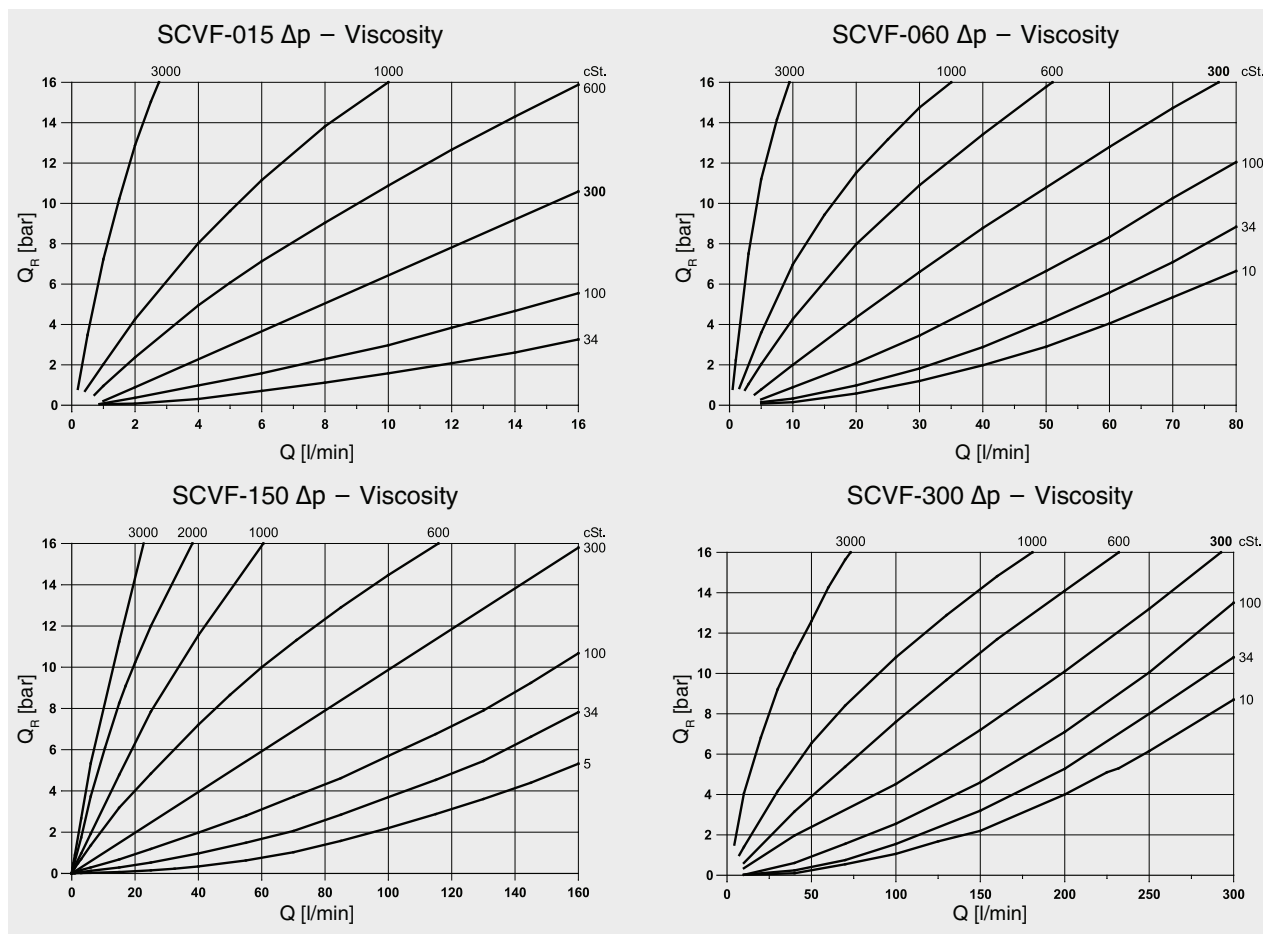

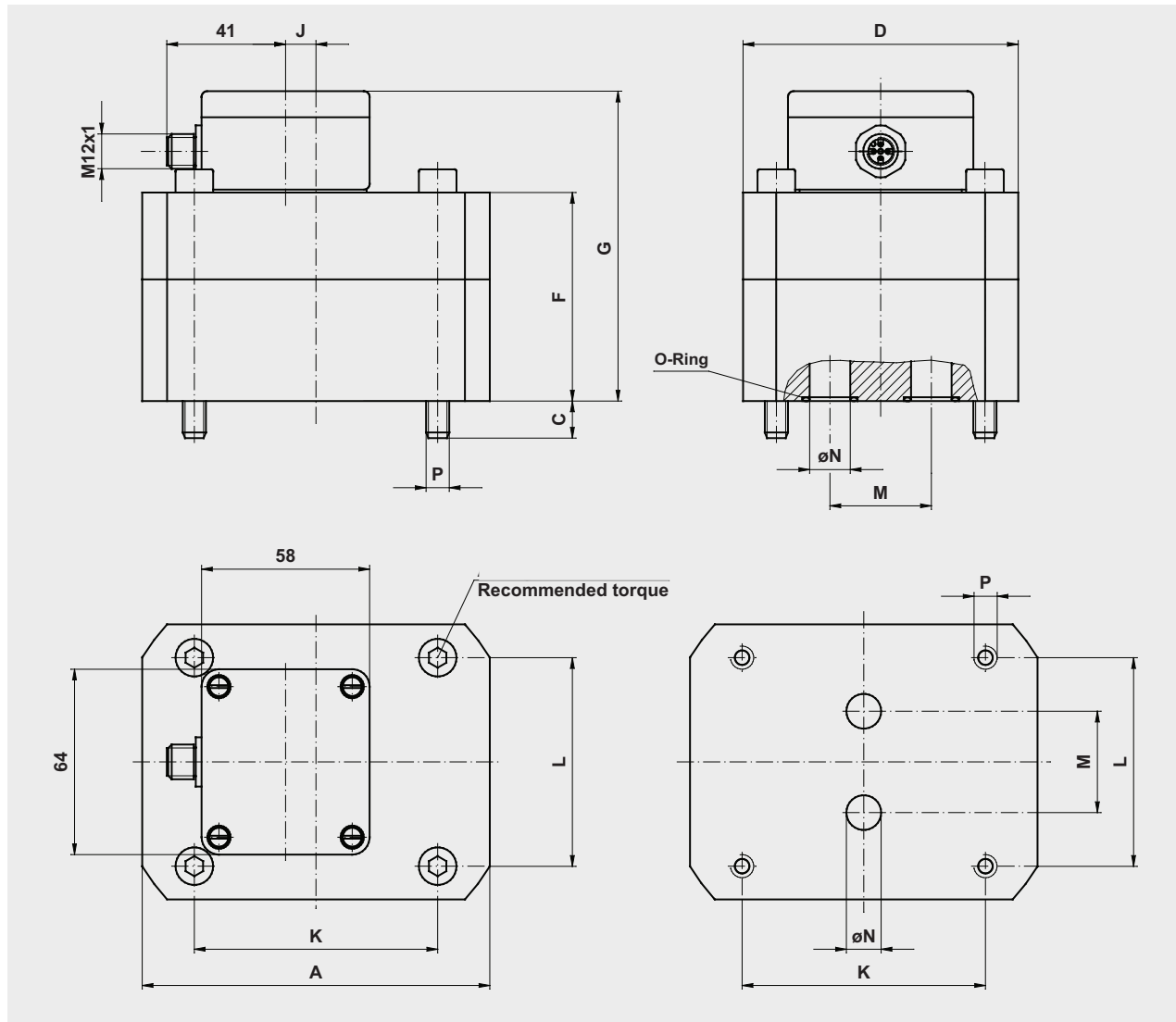

Type	Weight (kg)	Torque (Nm)	A	C	D	F	G	J	K	L	M	øN	P
SCVF-015	2	14	85	13	60	57	94	-	70	40	20	9	M6
SCVF-060	5,2	35	120	13	95	72	109	10,5	84	72	35	16	M8
SCVF-150	9	120	170	18	120	89	140	46,5	46	95	50	25	M12
SCVF-300	13	120	170	22	120	105	142	40	46	95	50	25	M12

all measurements in mm

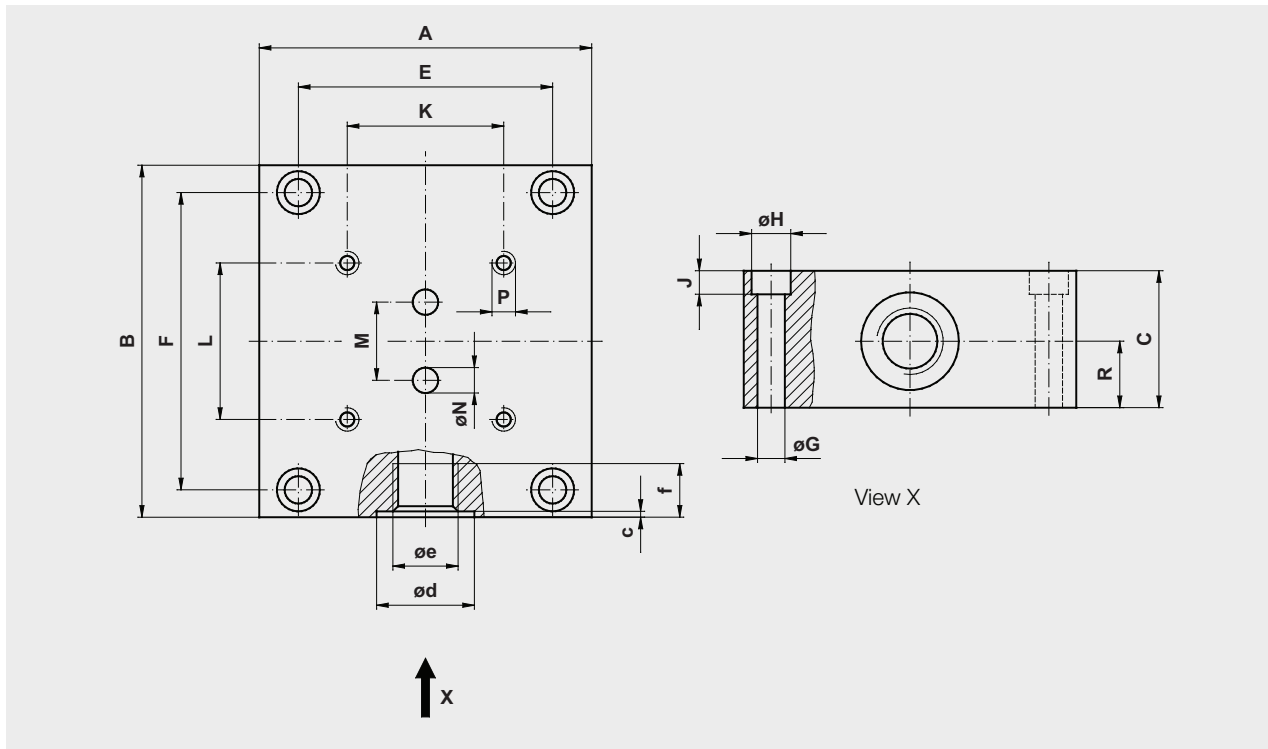

Type	(kg)	A	B	C	E	F	$\varnothing G$	$\varnothing H$	J	K	L	M	$\varnothing N$	P	R	c	$\varnothing d$	$\varnothing e$ BSPP	f
SCVF-015	1,8	85	90	35	65	76	7	11	7	70	40	20	6,5	M6/t=14	17	0,7	25	3/8"	13
SCVF-060	2,9	100	120	37	80	106	7	11	7	84	72	35	12	M8/t=18	17,5	0,7	29	1/2"	15
SCVF-150 SCVF-300	14	160	165	80	140	145	9	15	9	46	95	50	25	M12/t=24	28	1	42	1"	19

all measurements in mm