

# Operating Instructions

## Indumax CLS54

Conductivity sensor

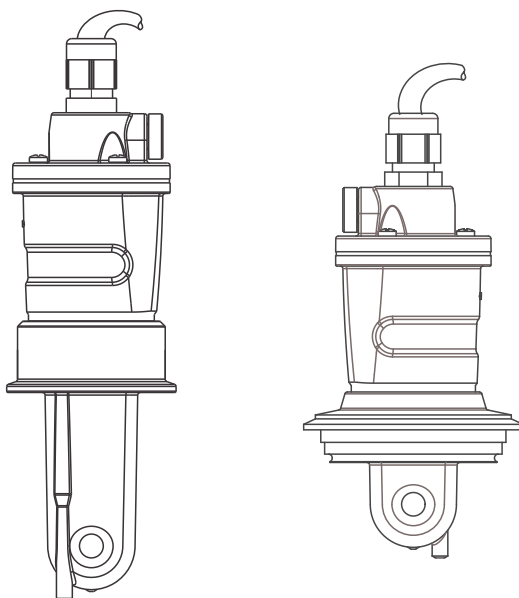







# Table of contents



<b>1</b>	<b>Document information</b>	<b>4</b>
1.1	Warnings	4
1.2	Symbols used	4
1.3	Symbols on the device	4
<b>2</b>	<b>Basic safety instructions</b>	<b>5</b>
2.1	Requirements for the personnel	5
2.2	Designated use	5
2.3	Occupational safety	5
2.4	Operational safety	6
2.5	Product safety	6
<b>3</b>	<b>Incoming acceptance and product identification</b>	<b>7</b>
3.1	Incoming acceptance	7
3.2	Scope of delivery	7
3.3	Product identification	8
3.4	Certificates and approvals	9
<b>4</b>	<b>Installation</b>	<b>10</b>
4.1	Measuring system	10
4.2	Design	11
4.3	Installation conditions	11
4.4	Installation	14
4.5	Dimensions	15
4.6	Post-installation check	17
<b>5</b>	<b>Electrical connection</b>	<b>18</b>
5.1	Connecting to the transmitter	18
5.2	Ensuring the degree of protection	18
5.3	Post-connection check	19
<b>6</b>	<b>Maintenance</b>	<b>20</b>
<b>7</b>	<b>Repairs</b>	<b>20</b>
7.1	Return	20
7.2	Disposal	20
<b>8</b>	<b>Accessories</b>	<b>21</b>
8.1	Cable extension	21
8.2	Calibration solutions	21
<b>9</b>	<b>Technical data</b>	<b>22</b>
	<b>Index</b>	<b>26</b>

# 1 Document information

## 1.1 Warnings

Structure of information	Meaning
 <p><b>Causes (/consequences)</b> Consequences of non-compliance (if applicable) ▶ Corrective action</p>	<p>This symbol alerts you to a dangerous situation. Failure to avoid the dangerous situation <b>will</b> result in a fatal or serious injury.</p>
 <p><b>Causes (/consequences)</b> Consequences of non-compliance (if applicable) ▶ Corrective action</p>	<p>This symbol alerts you to a dangerous situation. Failure to avoid the dangerous situation <b>can</b> result in a fatal or serious injury.</p>
 <p><b>Causes (/consequences)</b> Consequences of non-compliance (if applicable) ▶ Corrective action</p>	<p>This symbol alerts you to a dangerous situation. Failure to avoid this situation can result in minor or more serious injuries.</p>
 <p><b>Cause/situation</b> Consequences of non-compliance (if applicable) ▶ Action/note</p>	<p>This symbol alerts you to situations which may result in damage to property.</p>

## 1.2 Symbols used

-  Additional information, tips
-  Permitted or recommended
-  Forbidden or not recommended

## 1.3 Symbols on the device

Symbol	Meaning
	Reference to device documentation

## 2 Basic safety instructions

### 2.1 Requirements for the personnel

- Installation, commissioning, operation and maintenance of the measuring system may be carried out only by specially trained technical personnel.
- The technical personnel must be authorized by the plant operator to carry out the specified activities.
- The electrical connection may be performed only by an electrical technician.
- The technical personnel must have read and understood these Operating Instructions and must follow the instructions contained therein.
- Measuring point faults may be repaired only by authorized and specially trained personnel.



Repairs not described in the Operating Instructions provided may only be carried out directly by the manufacturer or by the service organization.

### 2.2 Designated use

Indumax CLS54 is designed for the inductive measurement of the conductivity of liquids. The sensor is particularly suitable for use in hygienic applications in the food, beverage, pharmaceutical and biotech industry.

Use with the Liquiline CM42 and Lquisys CLM223/253 transmitters; integral part of the Smartec CLD134 measuring system.

Use of the device for any purpose other than that described, poses a threat to the safety of people and of the entire measuring system and is therefore not permitted.

The manufacturer is not liable for damage caused by improper or non-designated use.

### 2.3 Occupational safety

As the user, you are responsible for complying with the following safety conditions:

- Installation guidelines
- Local standards and regulations

#### **Electromagnetic compatibility**

- The product has been tested for electromagnetic compatibility in accordance with the applicable European standards for industrial applications.
- The electromagnetic compatibility indicated applies only to a product that has been connected in accordance with these Operating Instructions.

## 2.4 Operational safety

1. Before commissioning the entire measuring point, verify that all connections are correct. Ensure that electrical cables and hose connections are undamaged.
2. Do not operate damaged products, and safeguard them to ensure that they are not operated inadvertently. Label the damaged product as defective.
3. If faults cannot be rectified:  
Take the products out of operation and safeguard them to ensure that they are not operated inadvertently.

## 2.5 Product safety

### 2.5.1 State of the art

The product is designed to meet state-of-the-art safety requirements, has been tested, and left the factory in a condition in which it is safe to operate. The relevant regulations and European standards have been observed.

## 3 Incoming acceptance and product identification

### 3.1 Incoming acceptance

1. Verify that the packaging is undamaged.
  - ↳ Notify your supplier of any damage to the packaging.  
Keep the damaged packaging until the matter has been settled.
2. Verify that the contents are undamaged.
  - ↳ Notify your supplier of any damage to the delivery contents.  
Keep the damaged products until the matter has been settled.
3. Check the delivery for completeness.
  - ↳ Check it against the delivery papers and your order.
4. Pack the product for storage and transportation in such a way that it is protected against impact and moisture.
  - ↳ The original packaging offers the best protection.  
The permitted ambient conditions must be observed (see "Technical data").

If you have any questions, please contact your supplier or your local sales center.

### 3.2 Scope of delivery

The scope of delivery includes:

- Sensor in the version ordered
- Operating Instructions

## 3.3 Product identification

### 3.3.1 Nameplate

The nameplate can be found on the sensor.

The following information is provided on the nameplate:

- Manufacturer identification
- Order code
- Extended order code
- Serial number
- Cell constant (nominal value)
- Protection class
- Pressure specification at 20 °C
- Continuous service temperature



Compare the data on the nameplate with your order.

### 3.3.2 Product identification

The order code and serial number of your product can be found in the following locations:

- On the nameplate
- In the delivery papers

#### Obtaining information on the product

1. Go to the product page for your product on the Internet.
2. In the navigation area on the right-hand side, select "Check your device features" under "Device support".
  - ↳ An additional window opens.
3. Enter the order code from the nameplate into the search field.
  - ↳ You will receive information on each feature (selected option) of the order code.



## 3.4 Certificates and approvals

### 3.4.1 Hygiene

#### FDA

All materials in contact with the product are listed by the FDA.

#### EHEDG

Certified cleanability according to EHEDG TYPE EL-class I.



When using the sensor in hygienic applications, please note that the cleanability of the sensor also depends on the way the sensor is installed. To install the sensor in a pipe, use the appropriate and EHEDG-certified flow vessels for the particular process connection.

#### 3-A

Certified according to 3-A Standard 74- ("3-A Sanitary Standards for Sensor and Sensor Fittings and Connections Used on Milk and Milk Products Equipment").

#### Biological reactivity (USP class VI) (option)

Biological reactivity test certificate (Certificate of Compliance) according to USP (United States Pharmacopoeia) part <87> and part <88> class VI with lot number traceability of materials in contact with the medium.

### 3.4.2 Ex approvals

- ATEX II 1G Ex ia IIC T3/T4/T6
- CSA IS/NI Cl. I Div. 1 & 2 GP A - D in conjunction with the Liquiline M CM42 transmitter

### 3.4.3 Regulation (EC) No. 1935/2004

Meets the requirements of Regulation (EC) No. 1935/2004

### 3.4.4 Pressure approval

Canadian pressure approval for pipes according to ASME B31.3

### 3.4.5 CE mark

The product meets the requirements of the harmonized European standards. As such, it complies with the legal specifications of the EC directives. The manufacturer confirms successful testing of the product by affixing to it the CE mark.

## 4 Installation

### 4.1 Measuring system

A complete measuring system consists of the following components at least:

- The CLS54 inductive conductivity sensor
- A transmitter, e.g. Liquiline CM42

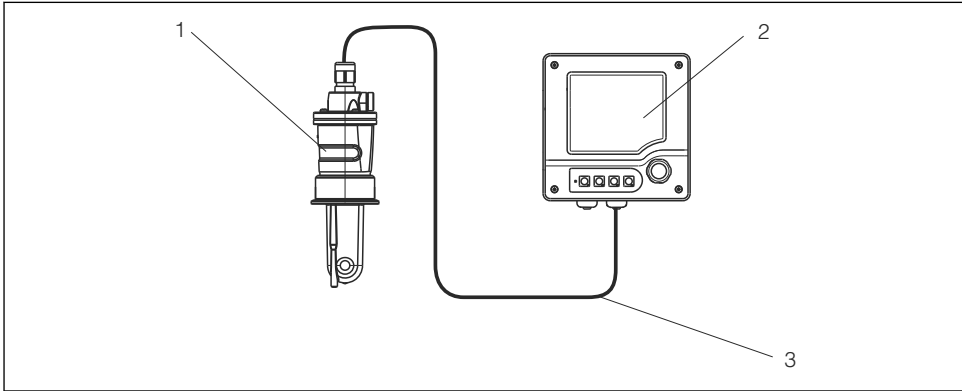

A0005431

 1 Example of a measuring system

- 1 Indumax CLS54
- 2 Liquiline CM42 transmitter
- 3 Measuring cable

## 4.2 Design

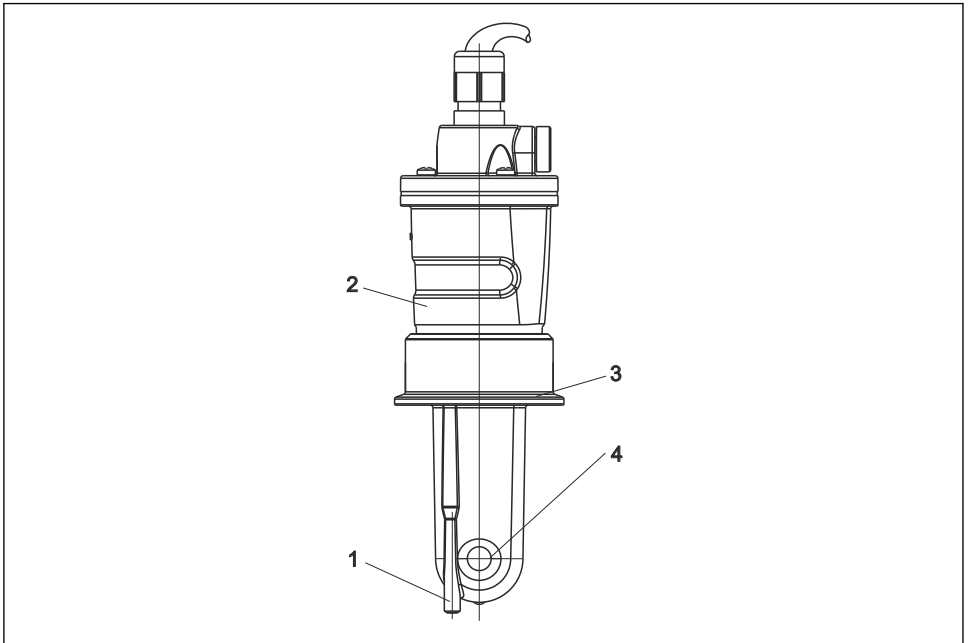

A0005430

### 2 Indumax CLS54

- 1 Temperature sensor
- 2 Housing
- 3 Process connection
- 4 Flow opening

## 4.3 Installation conditions

### 4.3.1 Orientation

The sensor must be completely immersed in the medium. Avoid air bubbles in the area of the sensor.

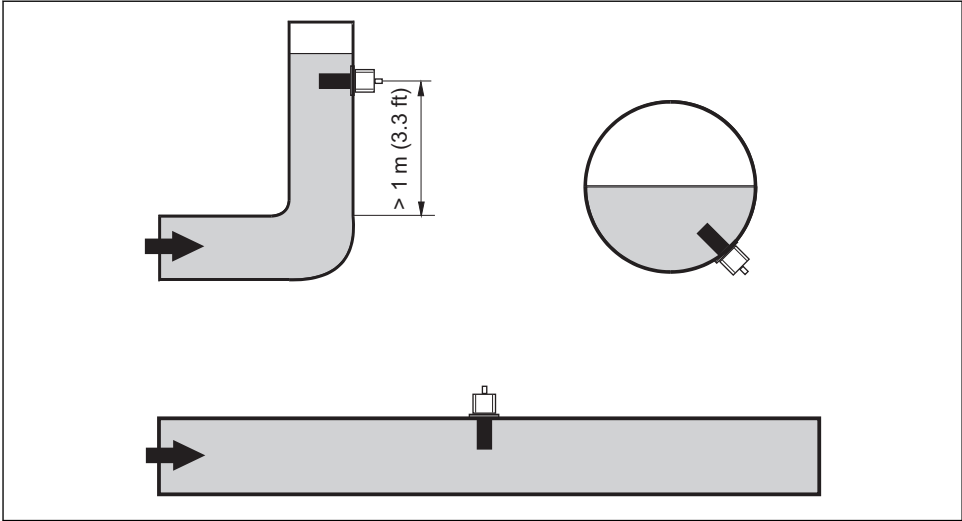

A0017691

### 3 Installation positions of the conductivity sensor

**i** If the flow direction changes (after pipe bends), turbulence in the medium can result. Install the sensor at a distance of at least 1 m (3.3 ft) downstream from a pipe bend.

**i** For a 3-A compliant installation, the following must be noted:

After the instrument is installed its hygienic integrity shall be maintained. All process connections must be 3-A compliant.

### 4.3.2 Installation factor

The ionic current in the liquid is affected by the walls in confined installation conditions. This effect is compensated by what is referred to as the installation factor. The installation factor can be entered in the transmitter for the measurement or the cell constant is corrected by multiplying by the installation factor.

The value of the installation factor depends on the diameter and the conductivity of the pipe nozzle as well as the distance  $a$  between the sensor and the wall.

The installation factor  $f$  ( $f = 1.00$ ) can be disregarded if the distance to the wall is sufficient ( $a > 15$  mm, from DN 65).

If the distance to the wall is smaller, the installation factor increases for electrically insulating pipes ( $f > 1$ ), and decreases for electrically conductive pipes ( $f < 1$ ).

It can be measured using calibration solutions, or a close approximation can be determined from the diagram below.

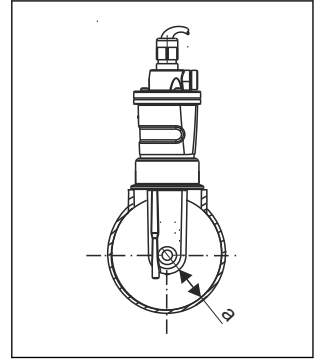

A0005453

4 CLS54 installation

$a$  Wall distance

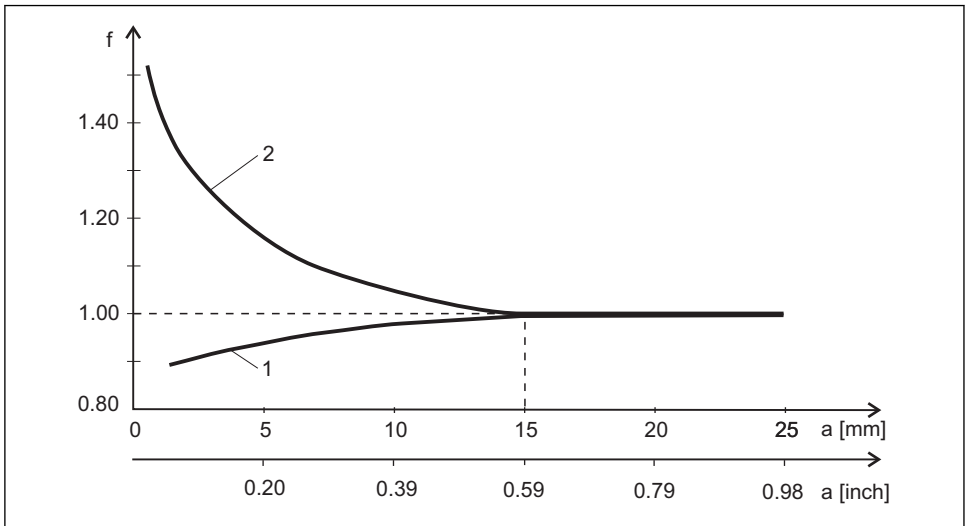

A0005441

5 Relationship between installation factor  $f$  and wall distance  $a$

- 1 Electrically conductive pipe wall
- 2 Electrically insulating pipe wall

### 4.3.3 Air set

To compensate residual coupling in the cable and between the two sensor coils, zero adjustment in air ("air set") must be performed before installing the sensor. Follow the instructions provided in the Operating Instructions of the transmitter used.

## 4.4 Installation

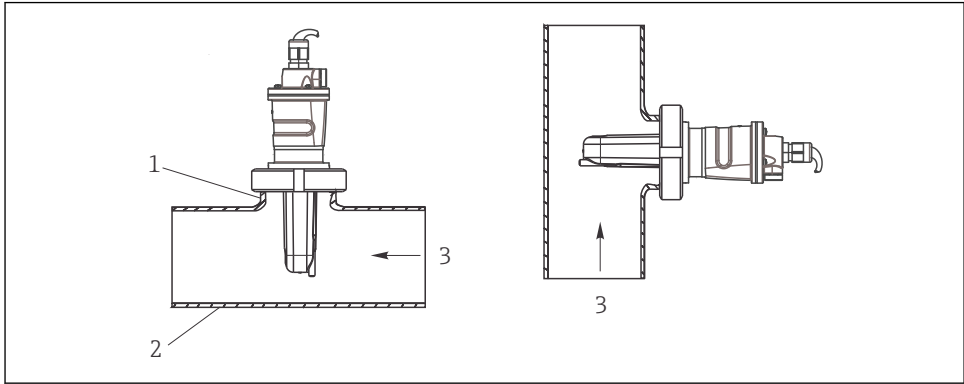

A0028428

### 6 CLS54 installation

- 1 Welding socket
- 2 Pipe
- 3 Direction of flow

When installing, align the sensor in such a way that the medium flows through the flow opening of the sensor in the direction of medium flow. The sensor head must be completely immersed in the medium.

The symmetrical measuring channel allows flow in both directions.

### 4.5 Dimensions

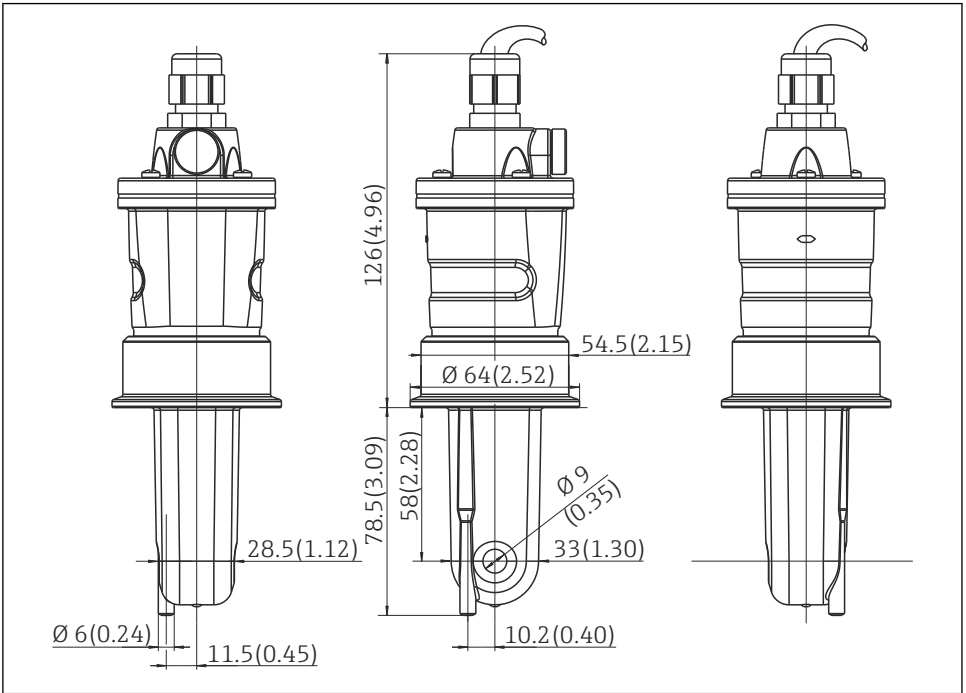

A0005429

7 Dimensions in mm(inch) (long version)

### 4.5.1 Process connections

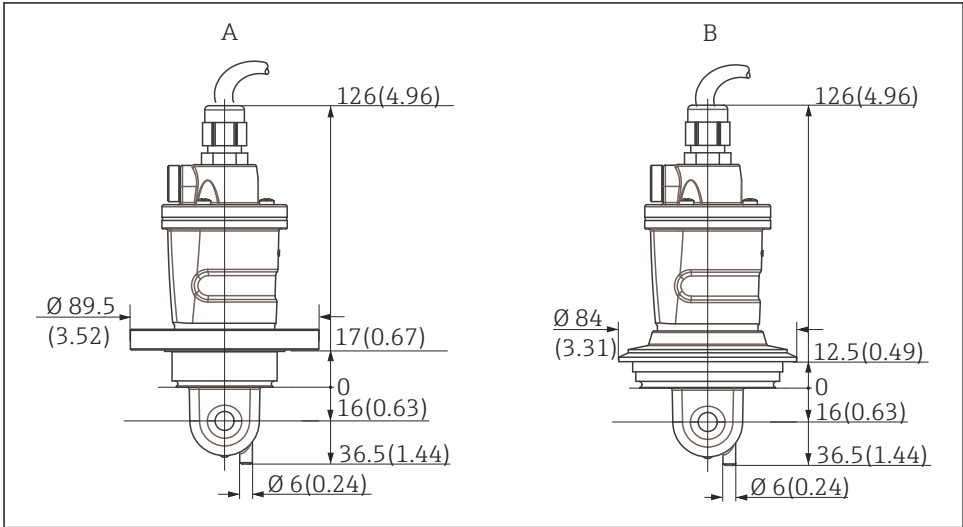

A0004949

**8** Process connections for CLS54 (short version), dimensions in mm (inch)

- A NEUMO BioControl D50 for pipe connection: DN 40 (DIN 11866 series A, DIN 11850); DN 42.4 (DIN 11866 series B, DIN EN ISO 1127); 2" (DIN 11866 series C, ASME-BPE)
- B Varivent N DN 40 to 125



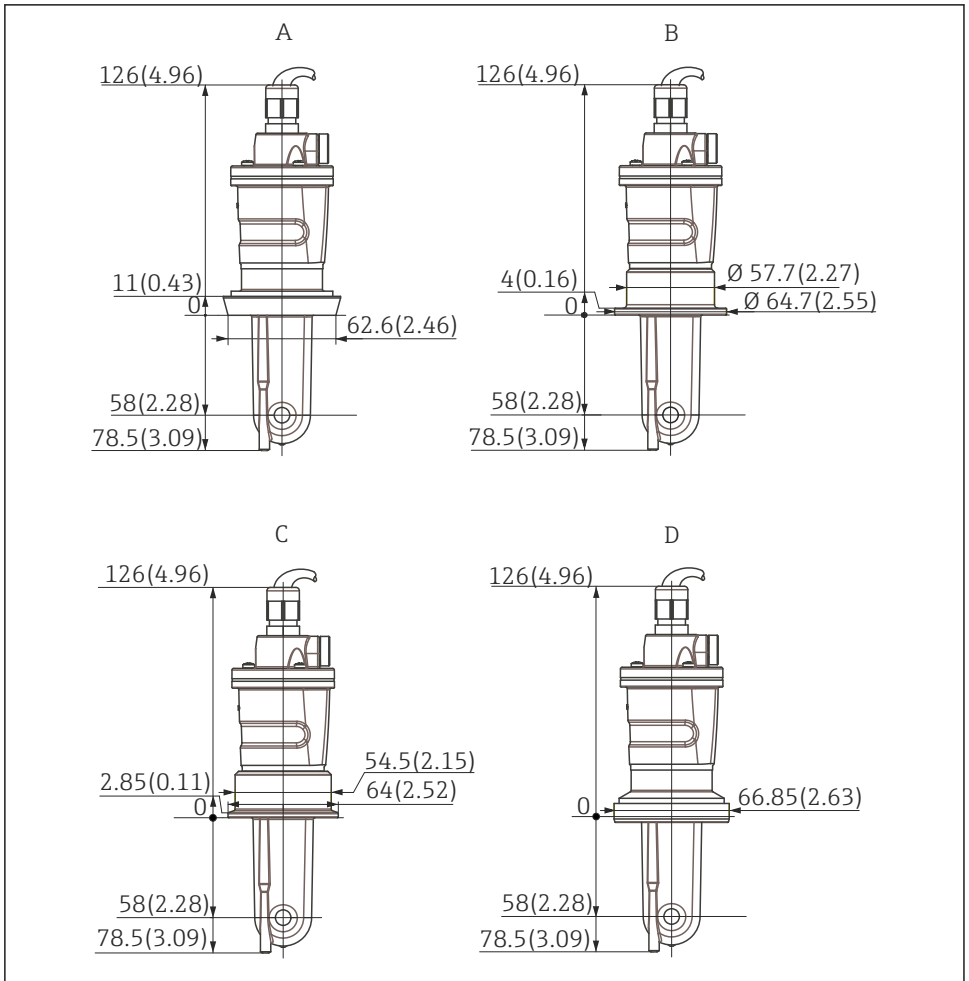

A0005436

9 Process connections for CLS54 (long version), dimensions in mm (inch)

- A Sanitary connection DIN 11851, DN 50
- B SMS coupling 2"
- C Clamp ISO 2852, 2"
- D Aseptic coupling DIN 11864-1 form A, for pipe according to DIN 11850, DN 50

## 4.6 Post-installation check

Put the sensor into operation only if you can answer "yes" to the following questions:

- Are the sensor and cable undamaged?
- Is the orientation correct?
- Has the sensor been installed in the process connection, and does not suspend freely from the cable?

## 5 Electrical connection

### **⚠ WARNING**

#### Device is live

Incorrect connection may result in injury or death.

- ▶ The electrical connection may be performed only by an electrical technician.
- ▶ The electrical technician must have read and understood these Operating Instructions and must follow the instructions contained therein.
- ▶ **Prior** to commencing connection work, ensure that no voltage is present on any cable.

### 5.1 Connecting to the transmitter

The sensor is supplied with a fixed cable. The wiring diagram is provided in the Operating Instructions of the transmitter used.

Connection via a VBM junction box is necessary for a cable connection. The extension to the transmitter is via the CLK6 cable.

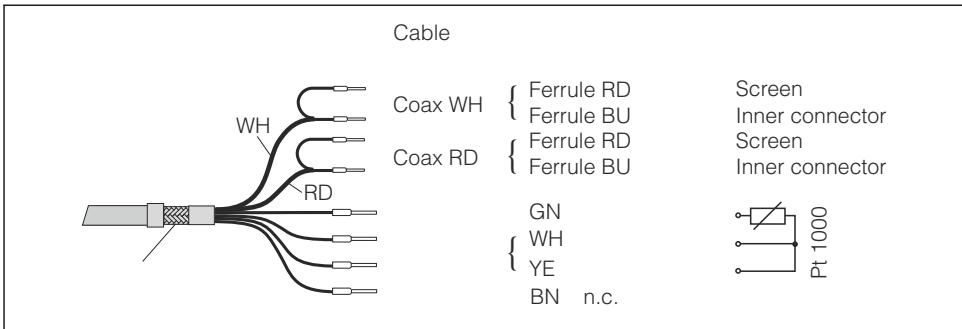

A0005433-EN

10 Fixed cable/special measuring cable CLK6

Cable length:

Max. total length of 55 m (180 ft)

### 5.2 Ensuring the degree of protection

Only the mechanical and electrical connections which are described in these instructions and which are necessary for the required, designated use, may be carried out on the device delivered.

- ▶ Exercise care when carrying out the work.

Otherwise, the individual types of protection (Ingress Protection (IP), electrical safety, EMC interference immunity) agreed for this product can no longer be guaranteed due, for example, to covers being left off or cable (ends) which are loose or insufficiently secured.

### 5.3 Post-connection check

Device condition and specifications	Notes
Are the outside of the sensor, assembly, cable undamaged?	Visual inspection
Electrical connection	Notes
Are the installed cables strain-relieved and not twisted?	
Is a sufficient length of the cable cores stripped, and is it positioned in the terminal correctly?	Check the fit (by pulling gently)
Are all the screws terminals properly tightened?	Tighten
Are all cable entries mounted, tightened and leak-tight?	For lateral cable entries, make sure the cables loop downwards to allow water to drip off
Are all cable entries installed downwards or mounted laterally?	

## 6 Maintenance

### CAUTION

#### **Risk of injury from cleaning agents, damage to clothing and equipment**

- ▶ Wear protective goggles and safety gloves.
- ▶ Clean away splashes on clothes and other objects.
- ▶ Pay particular attention to the information provided in the safety data sheets for the chemicals used.

As there is no galvanic contact with the medium, inductive sensors are considerably less sensitive to dirt and fouling than conventional conductive sensors.

However, dirt can clog the measuring channel which, in turn, can alter the cell constant. In such cases, an inductive sensor also needs to be cleaned.

Clean away fouling on the sensor as follows depending on the type of fouling:

- Oily and greasy films:  
Clean with grease remover, e.g. alcohol, acetone, possibly hot water and dishwashing detergent.
- Lime and metal hydroxide buildup:  
Dissolve buildup with diluted hydrochloric acid (3 %) and then rinse thoroughly with plenty of clear water.
- Sulfidic buildup (from flue gas desulfurization or sewage treatment plants):  
Use a mixture of hydrochloric acid (3 %) and thiocarbamide (commercially available) and then rinse thoroughly with plenty of clear water.
- Buildup containing proteins (e.g. food industry):  
Use a mixture of hydrochloric acid (0.5 %) and pepsin (commercially available) and then rinse thoroughly with plenty of clear water.

## 7 Repairs

### 7.1 Return

The product must be returned if repairs or a factory calibration are required, or if the wrong product was ordered or delivered. As an ISO-certified company and also due to legal regulations, Endress+Hauser is obliged to follow certain procedures when handling any returned products that have been in contact with medium.

To ensure swift, safe and professional device returns, please read the return procedures and conditions at [www.endress.com/support/return-material](http://www.endress.com/support/return-material).

### 7.2 Disposal

The device contains electronic components and must therefore be disposed of in accordance with regulations on the disposal of electronic waste.

Observe the local regulations.

## 8 Accessories

### 8.1 Cable extension

#### 8.1.1 Measuring cable

##### Measuring cable CLK6

- Extension cable for inductive conductivity sensors, for extension via VBM junction box
- Sold by the meter, order number: 71183688

#### 8.1.2 Junction box

##### VBM

- Junction box for cable extension
- 10 terminal strips
- Cable entries: 2 x Pg 13.5 or 2 x NPT ½"
- Material: aluminum
- Degree of protection: IP 65
- Order numbers
  - Cable entries Pg 13.5 : 50003987
  - Cable entries NPT ½": 51500177

##### Desiccant pouch

- Desiccant pouch with color indicator for VBM junction box
- Order No. 50000671

### 8.2 Calibration solutions

#### Conductivity calibration solutions CLY11

Precision solutions referenced to SRM (Standard Reference Material) by NIST for qualified calibration of conductivity measuring systems in accordance with ISO 9000

- CLY11-B, 149.6 µS/cm (reference temperature 25 °C (77 °F)), 500 ml (16.9 fl.oz)  
Order No. 50081903
- CLY11-C, 1.406 mS/cm (reference temperature 25 °C (77 °F)), 500 ml (16.9 fl.oz)  
Order No. 50081904
- CLY11-D, 12.64 mS/cm (reference temperature 25 °C (77 °F)), 500 ml (16.9 fl.oz)  
Order No. 50081905
- CLY11-E, 107.00 mS/cm (reference temperature 25 °C (77 °F)), 500 ml (16.9 fl.oz)  
Order No. 50081906



Technical Information TI00162C

## 9 Technical data

### 9.1 Input

#### 9.1.1 Measured values

- Conductivity
- Temperature

#### 9.1.2 Measuring range

Conductivity

Recommended range: 100  $\mu\text{S}/\text{cm}$  to 2000  $\text{mS}/\text{cm}$   
(uncompensated)

Temperature

-10 to +150 °C (+14 to +302 °F)

#### 9.1.3 Cell constant

$k = 6.3 \text{ cm}^{-1}$

#### 9.1.4 Temperature measurement

Pt1000 in accordance with DIN EN 60751

## 9.2 Performance characteristics

### 9.2.1 Temperature response time

$t_{90} \leq 26$  s

### 9.2.2 Maximum measured error

$\pm (0.5 \%$  of reading + 10  $\mu\text{S}/\text{cm}$ ) after calibration

(plus uncertainty of the conductivity of the calibration solution)

## 9.3 Environment

### 9.3.1 Ambient temperature range

-20 to +60 °C (0 to 140 °F)

### 9.3.2 Storage temperature

-25 to +80 °C (-13 to +176 °F)

### 9.3.3 Relative humidity

5 to 95 %

### 9.3.4 Degree of protection

IP 68 / NEMA type 6 (1 m (3.3 ft) water column, 50 °C (122 °F), 168 h)

## 9.4 Process

### 9.4.1 Process temperature

-10 to +125 °C (+14 to +257 °F)

### 9.4.2 Sterilization

150 °C (302 °F) / 5 bar (72.5 psi) (max. 60 min.)

### 9.4.3 Process pressure (absolute)

13 bar (188.5 psi) up to 90 °C (194 °F)

9 bar (130.5 psi) at 125 °C (257 °F)

1 to 6 bar (14.5 to 87 psi) in CRN environment tested with 50 bar (725 psi)

Underpressure down to 0.1 bar (1.45 psi)

### 9.4.4 Temperature-pressure ratings

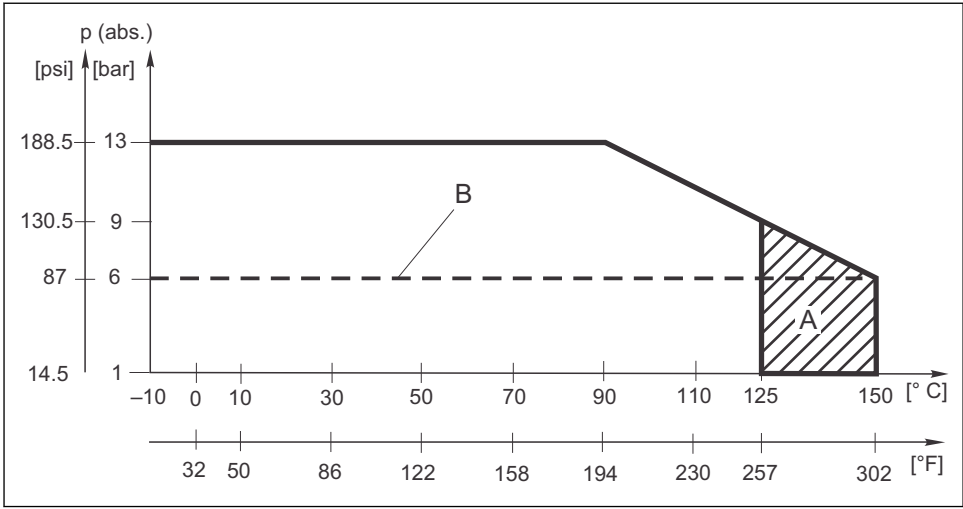

A0008379

11 Pressure/temperature ratings

A Temporarily for sterilization (max. 60 min.)

B MAWP (maximum allowable working pressure) according to ASME-BPVC Sec. VIII, Div 1 UG101 for CRN registration

## 9.5 Mechanical construction

### 9.5.1 Dimensions

→ Section "Installation"

### 9.5.2 Weight

0.3 to 0.5 kg (0.66 to 1.1 lb.) depending on version plus cable

### 9.5.3 Materials

In contact with medium

Virgin PEEK

Not in contact with medium

PPS-GF40

Stainless steel 1.4404 (AISI 316L)

Screws: 1.4301 (AISI 304)

Cable gland: PVDF

Seals: FKM, EPDM

Cable: TPE



#### 9.5.4 Surface roughness

$R_a \leq 0.8 \mu\text{m}$  (smooth, injection-molded PEEK surface) at surfaces in contact with medium

#### 9.5.5 Chemical resistance

Medium	Concentration	PEEK
Caustic soda NaOH	0 to 15 %	20 to 90 °C (68 to 194 °F)
Nitric acid HNO <sub>3</sub>	0 to 10 %	20 to 90 °C (68 to 194 °F)
Phosphoric acid H <sub>3</sub> PO <sub>4</sub>	0 to 15 %	20 to 80 °C (68 to 176 °F)
Sulfuric acid H <sub>2</sub> SO <sub>4</sub>	0 to 30 %	20 °C (68 °F)
Peracetic acid H <sub>3</sub> C-CO-OOH	0.2 %	20 °C (68 °F)

Errors and omissions excepted

# Index

## 0 ... 9

3-A . . . . . 9

## A

Accessories . . . . . 21

Air set . . . . . 13

Approvals . . . . . 9

## B

Biological reactivity . . . . . 9

## C

Certificates . . . . . 9

Chemical resistance . . . . . 25

## D

Design . . . . . 11

Designated use . . . . . 5

Dimensions . . . . . 15

Disposal . . . . . 20

## E

EHEDG . . . . . 9

Electrical connection . . . . . 18

Ensuring the degree of protection . . . . . 18

Environment . . . . . 23

## F

FDA . . . . . 9

## I

Incoming acceptance . . . . . 7

Input . . . . . 22

Installation . . . . . 10, 14

Installation conditions . . . . . 11

## M

Maintenance . . . . . 20

Measuring system . . . . . 10

Mechanical construction . . . . . 24

## N

Nameplate . . . . . 8

## P

Performance characteristics . . . . . 23

Post-connection check . . . . . 19

Post-installation check . . . . . 17

Process . . . . . 23

Process connections . . . . . 16

Product identification . . . . . 7

## R

Repairs . . . . . 20

Return . . . . . 20

## S

Safety instructions . . . . . 5

Scope of delivery . . . . . 7

Surface roughness . . . . . 25

Symbols . . . . . 4

## T

Technical data . . . . . 22

## U

Use . . . . . 5

## W

Warnings . . . . . 4

Wiring . . . . . 18





71314606

[www.addresses.endress.com](http://www.addresses.endress.com)

---